

439835 - 91
158651

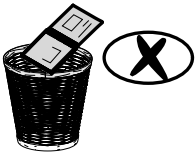

215939 V01

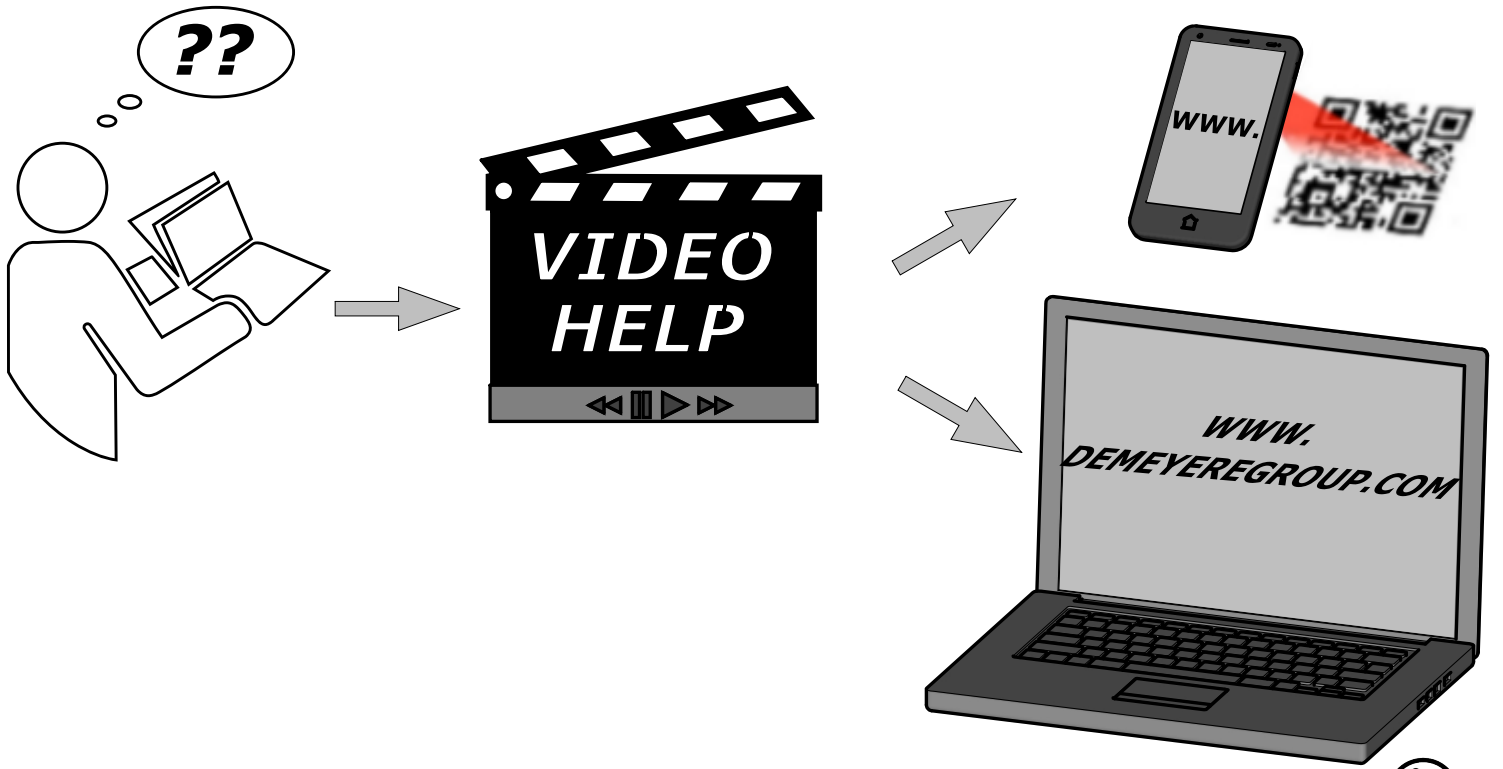

IMPORTANT - À lire attentivement - À conserver pour consultation ultérieure.
IMPORTANT - Please read carefully - Keep for future reference.
WICHTIG - Bitte sorgfältig lesen - Zum späteren Nachschlagen aufbewahren.
IMPORTANTE - Leer atentamente - Conservar para futuras consultas.
BELANGRIJK - Aandachtig lezen - Bewaren voor latere raadpleging.
IMPORTANTE - Leggere attentamente - Conservare per consultazione futura.
IMPORTANTE - Ler atentamente - Conservar para consulta futura.
WAŻNE - Przeczytać uważnie - Zachować do późniejszego wglądu.
VAŽNO - Pažljivo pročitati - Sačuvati za buduću upotrebu.
FONTOS - Gondosan olvassa el - Későbbi tájékozódás céljából őrizze meg.
 هام - يُرجى القراءة بعناية - يُحتفظ به للرجوع إليه لاحقاً -



Donnez ou recyclez vos meubles.



Association



Magasin



Déchèterie

<https://quefairemesdechets.fr>

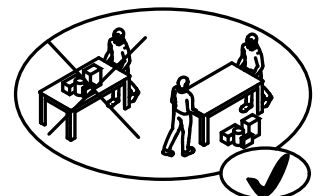
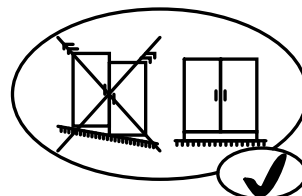
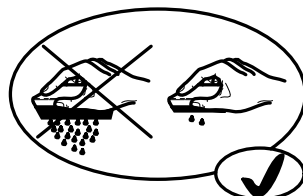
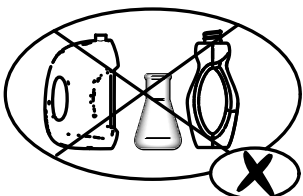
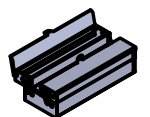
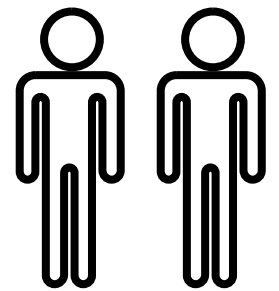
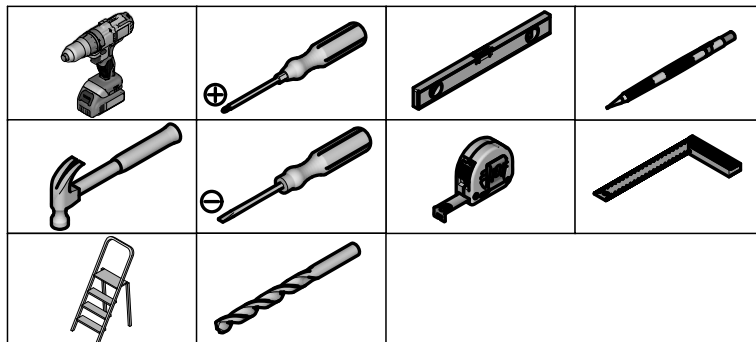



- A** x1
- B** x32
- C** x2
- D** x6
- E** x16
- F** x12
5x30mm
3/16" x 1 3/16"
- G** x14
8x30mm
5/16" x 1 3/16"
- H** x28
3x12mm
1/8" x 15/32"
- I** x32
3x16mm
1/8" x 5/8"
- J** x28
6,3x9mm
1/4" x 11/32"
- K** x24
3x12mm
1/8" x 15/32"
- L** x26
3,5x15mm
1/8" x 19/32"

- M** x2
- N** x14
- O** x6
Ø15mm
Ø19/32"
- P** x8
- Q** x4
- R** x8
Ø12mm
Ø15/32"
- S** x4
- T** x2
- U** x2
- V** x3
- X** x12
H=2mm
H=1/16"

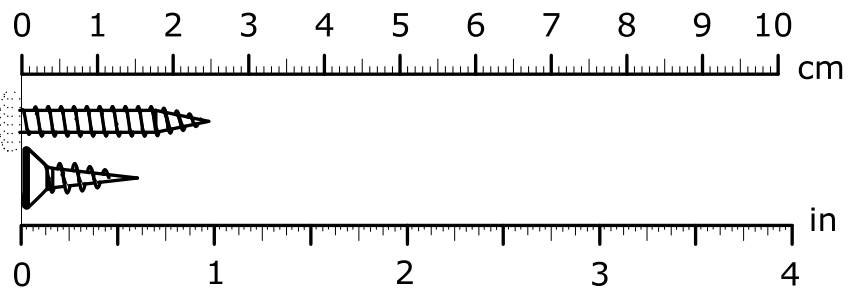

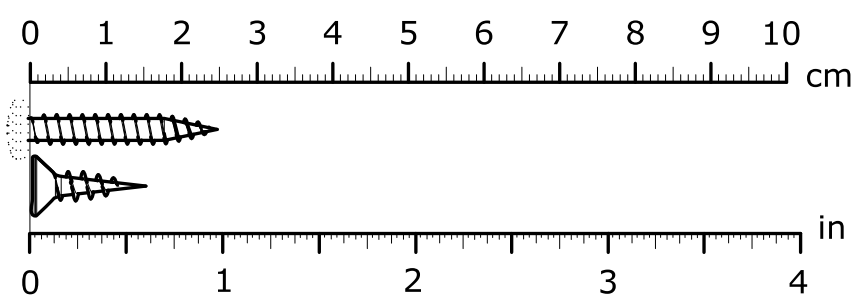
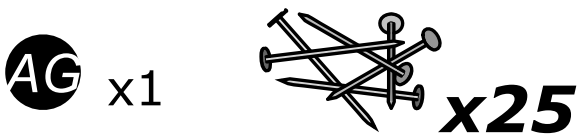
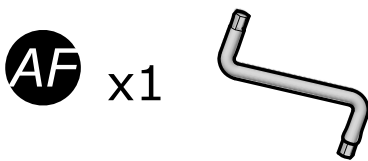
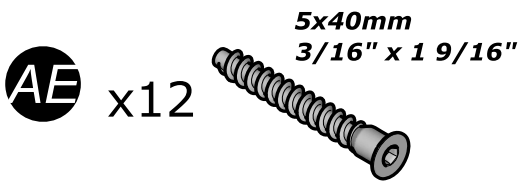
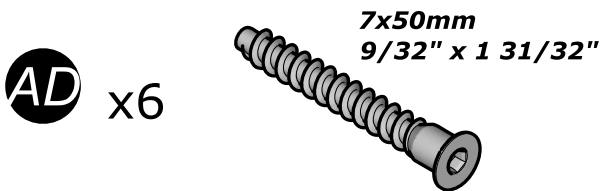
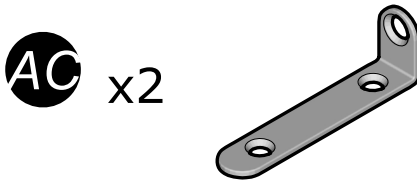
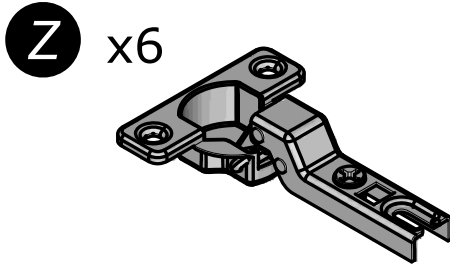
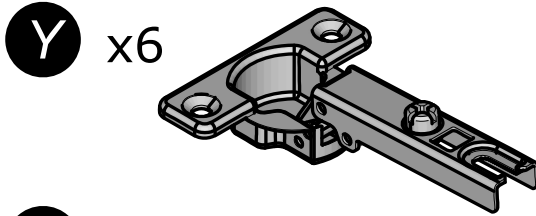

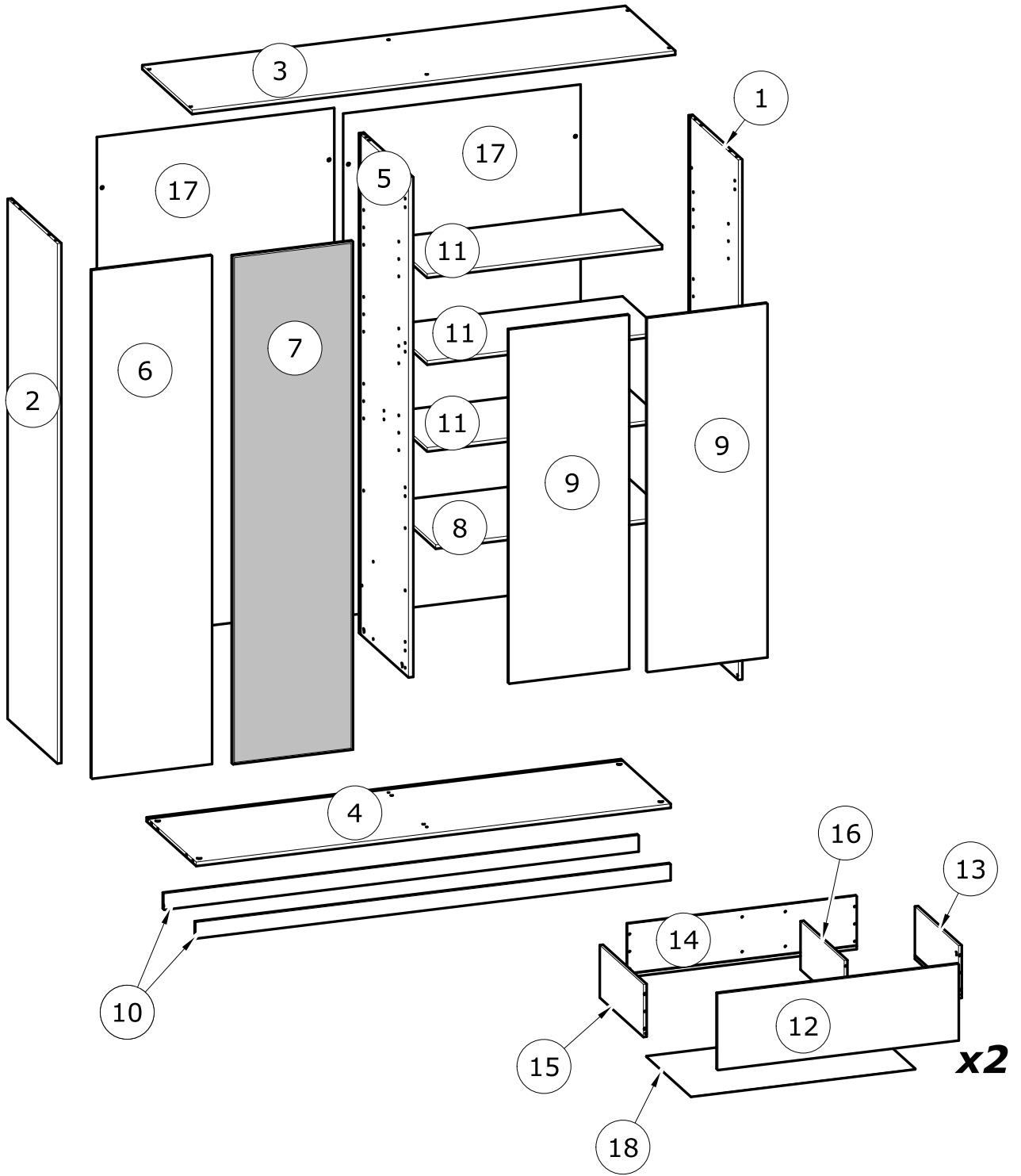

N°	MM		INCH		QTY
1	1 915	x 499	75 6/16	x 19 10/16	1
2	1 915	x 499	75 6/16	x 19 10/16	1
3	1 790	x 500	70 8/16	x 19 11/16	1
4	1 758	x 498	69 3/16	x 19 10/16	1
5	1 841	x 497	72 8/16	x 19 9/16	1
6	1 871	x 444	73 11/16	x 17 8/16	1
7	1 871	x 444	73 11/16	x 17 8/16	1
8	870	x 481	34 4/16	x 18 15/16	1
9	1 302	x 444	51 4/16	x 17 8/16	2

N°	MM		INCH		QTY
10	1 758	x 59	69 3/16	x 2 5/16	2
11	870	x 396	34 4/16	x 15 9/16	3
12	892	x 279	35 2/16	x 11	2
13	438	x 194	17 4/16	x 7 10/16	2
14	848	x 195	33 6/16	x 7 11/16	2
15	438	x 194	17 4/16	x 7 10/16	2
16	438	x 179	17 4/16	x 7 1/16	2
17	1 850	x 879	72 13/16	x 34 10/16	2
18	831	x 447	32 11/16	x 17 10/16	2

FR

AVERTISSEMENT : MEUBLE A FIXER IMPERATIVEMENT AU MUR AFIN D'EVITER SON BASCULEMENT

- Pour installer correctement ce produit et éliminer les risques pour votre sécurité, merci de suivre exactement ce manuel d'instruction.
- Fixer le meuble au mur avec les attaches prévues à cet effet
- Les vis et les chevilles ne sont pas fournies. Utiliser des vis et des chevilles adaptées au support.

EN

WARNING: FURNITURE TO BE ATTACHED TO THE WALL TO PREVENT OVERTURNING

- Installation shall be carried out exactly according to those instructions-otherwise a safety risk can occur if incorrectly installed;
- Attach the furniture to the wall with the fastening provided for this purpose
- Screw and Pegs are not supplied. Use Screws and pegs adapted to the support.

DE

WARNUNG: DAS MÖBEL MUSS AN DER WAND BEFESTIGT WERDEN, UM ZU VERHINDEN DASS ES KIPPT

- Um das Produkt korrekt zu installieren und um Risiken für Ihre Sicherheit zu verhindern, die Gebrauchsanleitung genauestens befolgen.
- Das Möbel mit den vorgesehenen Befestigungen an einer Wand befestigen.
- Schrauben und Dübel sind nicht im Lieferumfang enthalten. Passende Schrauben und Dübel verwenden.

ES

ADVERTENCIA: ESTE MUEBLE DEBE ESTAR SIEMPRE FIJO EN LA PARED PARA EVITAR QUE VUELQUE

- Para instalar correctamente este producto y eliminar los riesgos para la seguridad, seguir exactamente las instrucciones del manual.
- Fijar el mueble a la pared con las sujeciones previstas a este efecto.
- Los tornillos y los tacos no están incluidos. Utilizar tornillos y tacos adaptados al soporte.

NL

WAARSCHUWING: MEUBEL MOET VERPLICHT AAN DE MUUR BEVESTIGD WORDEN ZODAT HET NIET KAN OMVALLEN

- Om dit product correct te installeren en alle risico's voor uw veiligheid te elimineren, gelieve de instructies in deze handleiding nauwgezet op te volgen.
- Zet het meubel vast aan de muur met de hiertoe voorziene bevestigingen.
- De schroeven en pluggen zijn niet meegeleverd. Gebruik schroeven en pluggen die geschikt zijn voor het materiaal van de muur.

IT

AVVERTENZA: MOBILE DA FISSARE IMPERATIVAMENTE AL MURO PER EVITARE CHE SI RIBALTI

- Per installare correttamente questo prodotto ed eliminare i rischi per la vostra sicurezza, si prega di seguire esattamente il manuale d'istruzioni.
- Fissare il mobile al muro con gli appositi ganci.
- Le viti e i tasselli non sono forniti. Utilizzare viti e tasselli adatti al supporto.

PT

ADVERTÊNCIA: MÓVEL A FIXAR OBRIGATORIAMENTE À PAREDE PARA EVITAR A SUA QUEDA

- Para instalar corretamente este produto e eliminar os riscos para a sua segurança, é favor seguir exatamente este manual de instruções.
- Fixe o móvel à parede com as fixações previstas para o efeito
- Os parafusos e as cavilhas não são fornecidos. Utilize parafusos e cavilhas adaptados ao suporte.

CR

UPOZORENJE : UČVRSTITE ORMARIĆ NA ZID KAKO BISTE SPRIJEČILI NJEGOVO LJULJANJE

- Kako biste pravilno postavili ovaj proizvod i uklonili sigurnosne rizike kojima se izlažete, pridržavajte se strogo ovog priručnika s uputama.
- Postavite ormarić na zid pripadajućim sponama.Vijci i svornjci ne isporučuju se. Upotrijebite nosne vijke i svornjke.

Hu

FIGYELEM: A BÚTORT FELTÉTENŰL RÖGZÍTENI KELL A FALHOZ, HOGY ELKERÜLJE A FELBILLENÉSÉT

- A termék megfelelő elhelyezéséhez és a biztonságot érintő kockázatok kiküszöböléséhez pontosan kövesse ezt a használati útmutatót.
- Rögzítse a bútort a falhoz az erre a célra szolgáló rögzítőelemekkel.
- A csavarok és a tiplik nincsenek mellékelve. Használjon a tartóhoz illő csavarokat és tipliket.

PL

OSTRZEŻENIE: MEBEL NALEŻY PRZYMOCOWAĆ DO ŚCIANY, ABY UNIKNĄĆ JEGO PRZEWRÓCENIA

- Aby prawidłowo zainstalować ten produkt i wyeliminować zagrożenie dla bezpieczeństwa użytkownika, należy postępować zgodnie z niniejszą instrukcją.
- Przymocować mebel do ściany za pomocą mocowań przewidzianych w tym celu.
- Śruby i nakrętki nie znajdują się w zestawie. Użyć śrub i nakrętek dostosowanych do wspornika.

العربية:

تحذير: قطعة أثاث يلزم تثبيتها على الحائط لتجنب تأرجحها

- لتركيب هذا المنتج بشكل صحيح وتجنب المخاطر من أجل سلامتك، يرجى اتباع كتيب التعليمات هذا بالضبط.
- تثبت قطعة الأثاث على الحائط بواسطة العلاقات المخصصة لهذا الغرض
- إن البراغي والحوابير غير متوفرة مع المنتج. تستخدم براغي وحوابير ملائمة للحائط الذي يتم التثبيت عليه.

FR

A monter soi-même. Vérifier la présence et l'état de la quincaillerie et des pièces avant de débiter le montage. Utiliser uniquement l'outillage fourni ou préconisé. Serrer correctement les éléments de fixation avec l'outillage fourni ou préconisé. Un mauvais montage, calage ou manutention peut entraîner une fragilisation des assemblages et/ou des Pièces. Tenir éloigné les jeunes enfants lors de l'assemblage. Présence de petites pièces susceptibles d'être ingérées.

EN

Self-assembly. Check the presence and condition of all hardware and parts before beginning assembly. Use only the tools provided or recommended. Tighten fasteners correctly with the tools provided or recommended. Improper assembly, wedging, or handling may weaken the assemblies and/or parts. Keep young children away during assembly. Small parts may be present and could be swallowed.

DE

Selbstmontage. Überprüfen Sie vor Beginn der Montage das Vorhandensein und den Zustand aller Beschläge und Teile. Verwenden Sie nur die mitgelieferten oder empfohlenen Werkzeuge. Ziehen Sie die Befestigungselemente mit den mitgelieferten oder empfohlenen Werkzeugen ordnungsgemäß fest. Unsachgemäße Montage, Verkeilen oder Handhabung können die Baugruppen und/oder Teile schwächen. Halten Sie kleine Kinder während der Montage fern. Es können Kleinteile vorhanden sein, die verschluckt werden könnten.

ES

Autoensamblaje. Compruebe la presencia y el estado de todos los herrajes y piezas antes de comenzar el ensamblaje. Utilice únicamente las herramientas proporcionadas o recomendadas. Apriete los sujetadores correctamente con las herramientas proporcionadas o recomendadas. Un ensamblaje, acuíñamiento o manipulación incorrectos pueden debilitar los conjuntos o las piezas. Mantenga a los niños pequeños alejados durante el ensamblaje. Puede haber piezas pequeñas que podrían ser ingeridas.

NL

Zelfmontage. Controleer de aanwezigheid en staat van alle hardware en onderdelen voordat u met de montage begint. Gebruik alleen het meegeleverde of aanbevolen gereedschap. Draai de bevestigingsmiddelen correct vast met het meegeleverde of aanbevolen gereedschap. Onjuiste montage, wiggen of behandeling kan de constructie en/of onderdelen verzwakken. Houd jonge kinderen uit de buurt tijdens de montage. Er kunnen kleine onderdelen aanwezig zijn die kunnen worden ingeslikt.

IT

Autoassemblaggio. Verificare la presenza e le condizioni di tutti gli elementi di fissaggio e dei componenti prima di iniziare il montaggio. Utilizzare solo gli utensili forniti o consigliati. Serrare correttamente i dispositivi di fissaggio con gli utensili forniti o consigliati. Un montaggio, un incastro o una manipolazione impropri possono indebolire i componenti e/o i componenti. Tenere lontani i bambini piccoli durante il montaggio. Potrebbero essere presenti piccole parti che potrebbero essere ingerite.

PT

Montagem por conta própria. Verifique a presença e o estado de todas as ferragens e peças antes de iniciar a montagem. Utilize apenas as ferramentas fornecidas ou recomendadas. Aperte os fixadores corretamente com as ferramentas fornecidas ou recomendadas. Montagem, calçamento ou manuseio inadequados podem enfraquecer os conjuntos e/ou peças. Mantenha crianças pequenas afastadas durante a montagem. Peças pequenas podem estar presentes e podem ser engolidas.

PL

Samodzielny montaż. Przed rozpoczęciem montażu sprawdź obecność i stan wszystkich elementów i części. Używaj wyłącznie dostarczonych lub zalecanych narzędzi. Dokręć elementy złączne prawidłowo za pomocą dostarczonych lub zalecanych narzędzi. Nieprawidłowy montaż, klinowanie lub obchodzenie się z elementami może osłabić zespoły i/lub części. Trzymaj małe dzieci z dala od montażu. Mogą występować drobne elementy, które mogą zostać połknięte.

CR

Samostalno sastavljanje. Prije početka sastavljanja provjerite prisutnost i stanje svih dijelova i okova. Koristite samo isporučenim ili preporučeni alat. Ispravno zategnite pričvršćivače isporučenim ili preporučeni alatima. Nepravilno sastavljanje, uklinjanje ili rukovanje mogu oslabiti sklopove i/ili dijelove. Držite malu djecu podalje tijekom sastavljanja. Mogu biti prisutni mali dijelovi koje bi djeca mogla progutati.

GR

Αυτοσυναρμολόγηση. Ελέγξτε την παρουσία και την κατάσταση όλων των εξαρτημάτων και των υλικών πριν ξεκινήσετε τη συναρμολόγηση. Χρησιμοποιήστε μόνο τα εργαλεία που παρέχονται ή συνιστώνται. Σφίξτε σωστά τα στοιχεία στερέωσης με τα εργαλεία που παρέχονται ή συνιστώνται. Η ακατάλληλη συναρμολόγηση, η σφήνωση ή ο χειρισμός μπορεί να αποδυναμώσουν τα συγκροτήματα ή/και τα εξαρτήματα. Κρατήστε τα μικρά παιδιά μακριά κατά τη συναρμολόγηση. Ενδέχεται να υπάρχουν μικρά εξαρτήματα και να τα καταπιείτε.

لعربية:

تحذير: قطعة أثاث يلزم تثبيتها على الحائط لتجنب تأرجحها

- **لتركيب هذا المنتج بشكل صحيح وتجنب المخاطر من أجل سلامتك، يرجى اتباع كتيب التعليمات هذا بالضبط.**
- **تثبيت قطعة الأثاث على الحائط بواسطة العلاقات المخصصة لهذا الغرض**
- **إن البراغى والخوابير غير متوفرة مع المنتج. تستخدم براغى وخوابير ملائمة للحائط الذي يتم التثبيت عليه.**

FR

Ne pas monter ou utiliser le mobilier si certains éléments sont cassés endommagés ou manquants, et n'utiliser que des pièces détachées approuvées par le fabricant.

EN

Do not assemble or use the furniture if any parts are broken, damaged or missing, and only use spare parts approved by the manufacturer.

DE

Montieren oder verwenden Sie die Möbel nicht, wenn Teile defekt, beschädigt oder fehlen, und verwenden Sie nur vom Hersteller zugelassene Ersatzteile.

ES

No monte ni utilice el mueble si alguna pieza está rota, dañada o falta y utilice únicamente repuestos aprobados por el fabricante.

NL

Monteer of gebruik het meubel niet als er onderdelen kapot, beschadigd of ontbreken. Gebruik alleen reserveonderdelen die door de fabrikant zijn goedgekeurd.

IT

Non montare o utilizzare i mobili se qualche parte è rotta, danneggiata o mancante e utilizzare solo pezzi di ricambio approvati dal produttore.

PT

Não monte nem utilize o móvel se alguma peça estiver quebrada, danificada ou faltando, e utilize somente peças de reposição aprovadas pelo fabricante.

PL

Nie należy montować ani użytkować mebli, jeśli jakkolwiek ich część jest uszkodzona, uszkodzona lub jej brakuje. Należy stosować wyłącznie części zamienne zatwierdzone przez producenta.

CR

Ne sastavljajte niti koristite namještaj ako su neki dijelovi slomljeni, oštećeni ili nedostaju te koristite samo rezervne dijelove koje je odobrio proizvođač.

GR

Μην συναρμολογείτε ή χρησιμοποιείτε τα έπιπλα εάν κάποια μέρη τους είναι σπασμένα, κατεστραμμένα ή λείπουν και χρησιμοποιείτε μόνο ανταλλακτικά εγκεκριμένα από τον κατασκευαστή.

العربية:

تحذير: قطعة أثاث يلزم تثبيتها على الحائط لتجنب تأرجحها

- لتركيب هذا المنتج بشكل صحيح وتجنب المخاطر من أجل سلامتك، يرجى اتباع كتيب التعليمات هذا بالضبط.
- تثبيت قطعة الأثاث على الحائط بواسطة العلاقات المخصصة لهذا الغرض
- إن البراغى والخوابير غير متوفرة مع المنتج. تستخدم براغى وخوابير ملائمة للحائط الذى يتم التثبيت عليه.

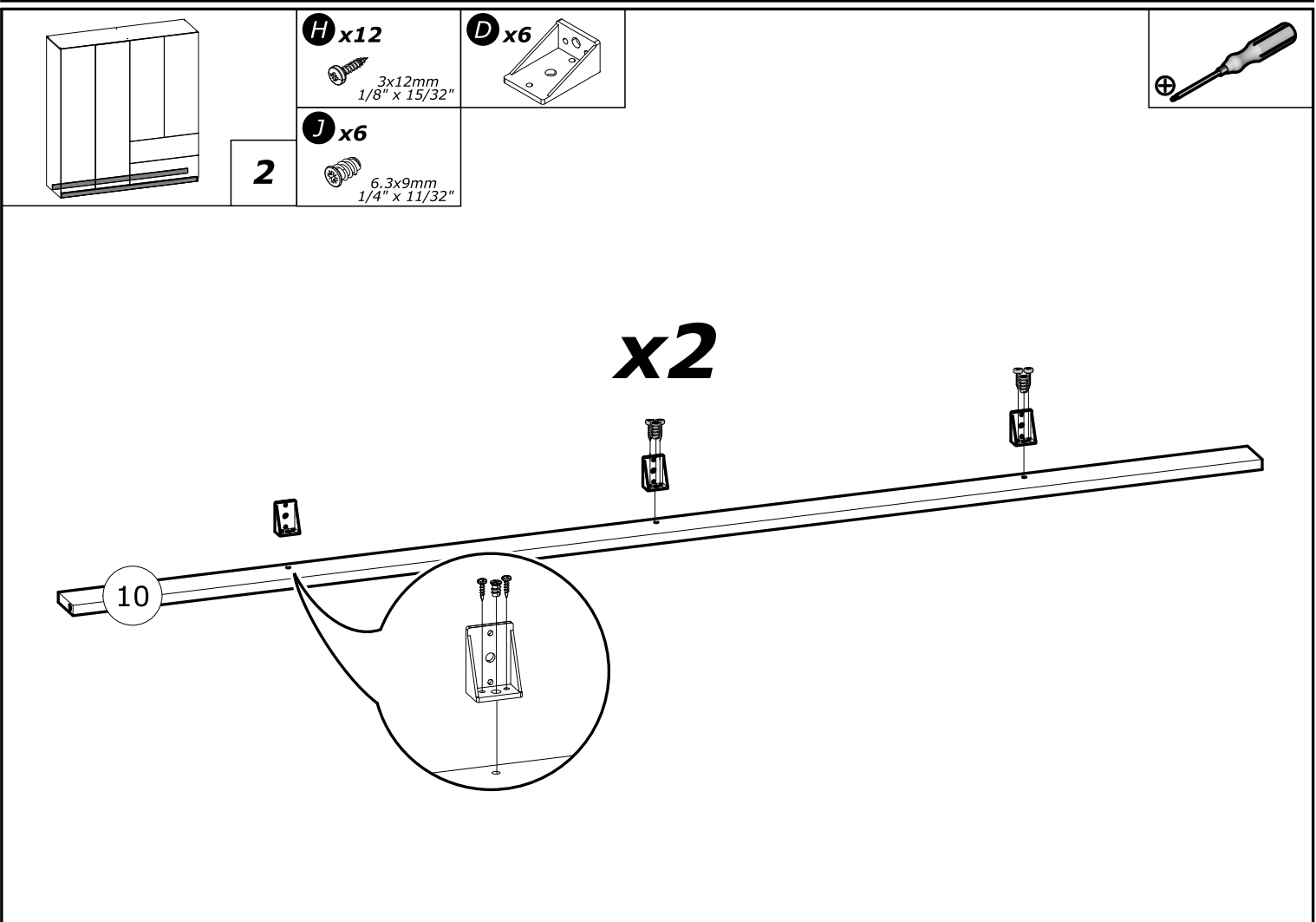
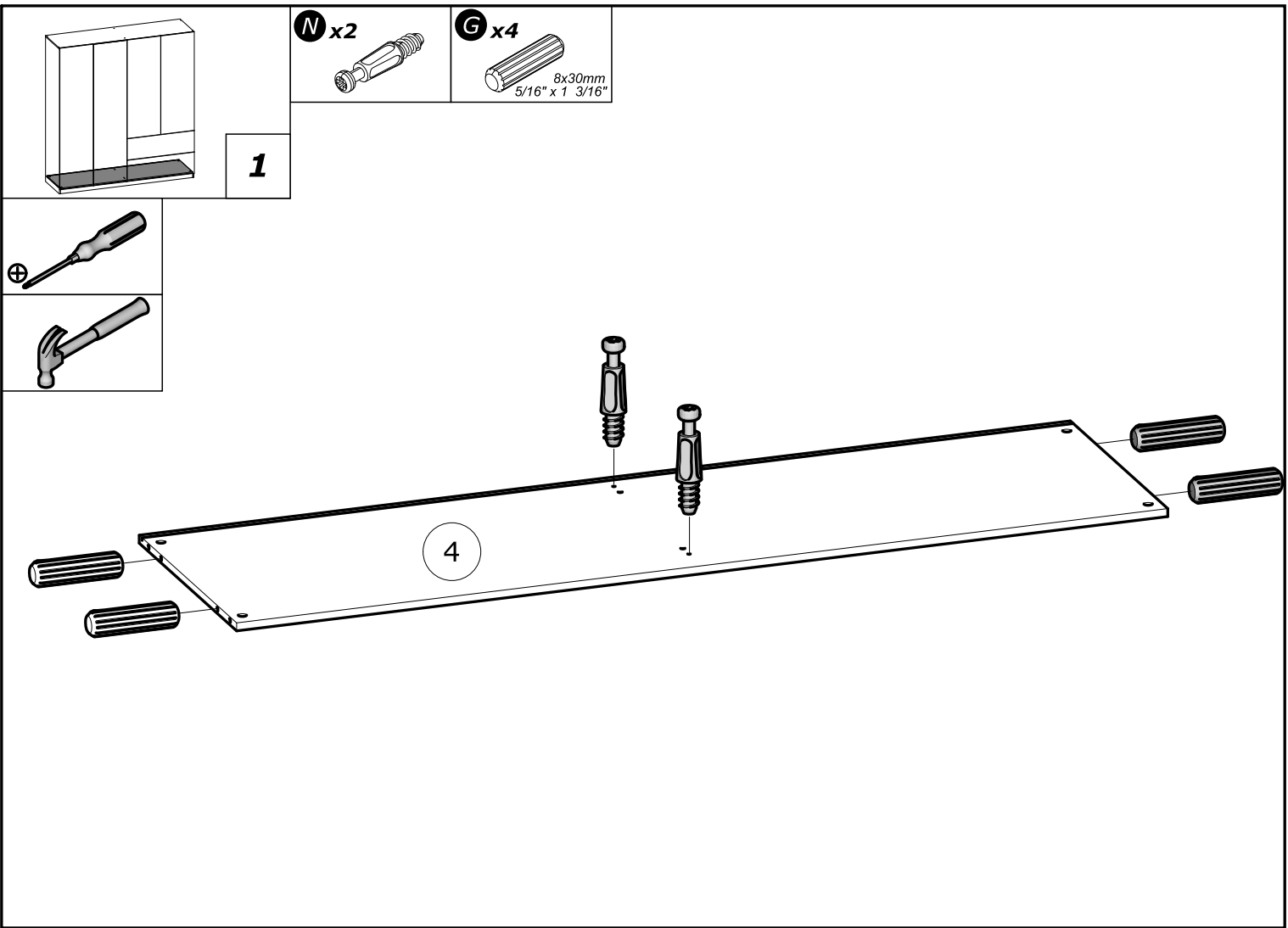

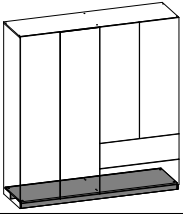

3

J x6
6.3x9mm
1/4" x 11/32"

H x12
3x12mm
1/8" x 15/32"

G x2
8x30mm
5/16" x 1 3/16"

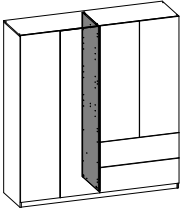
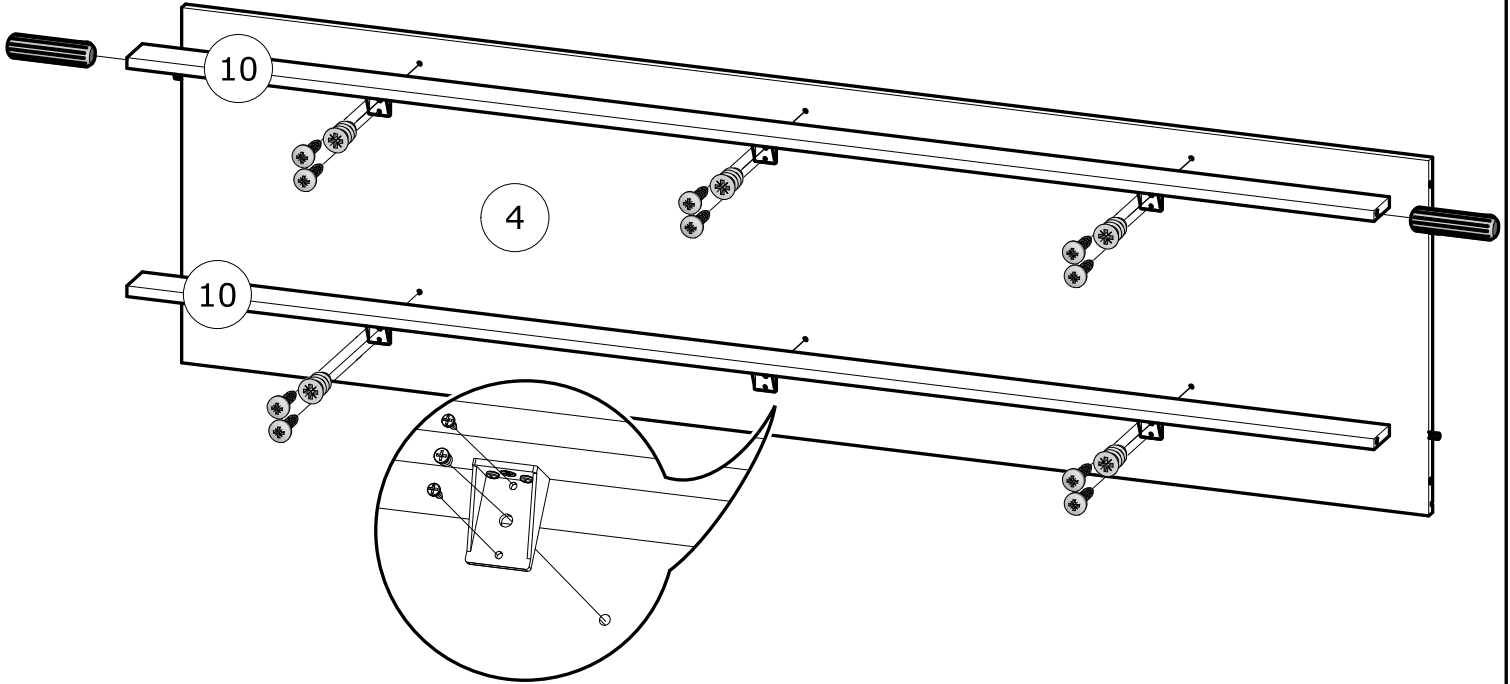
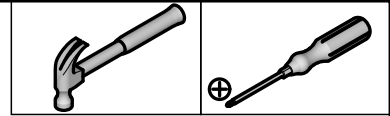

4

J x4
6.3x9mm
1/4" x 11/32"

K x2
3x12mm
1/8" x 15/32"

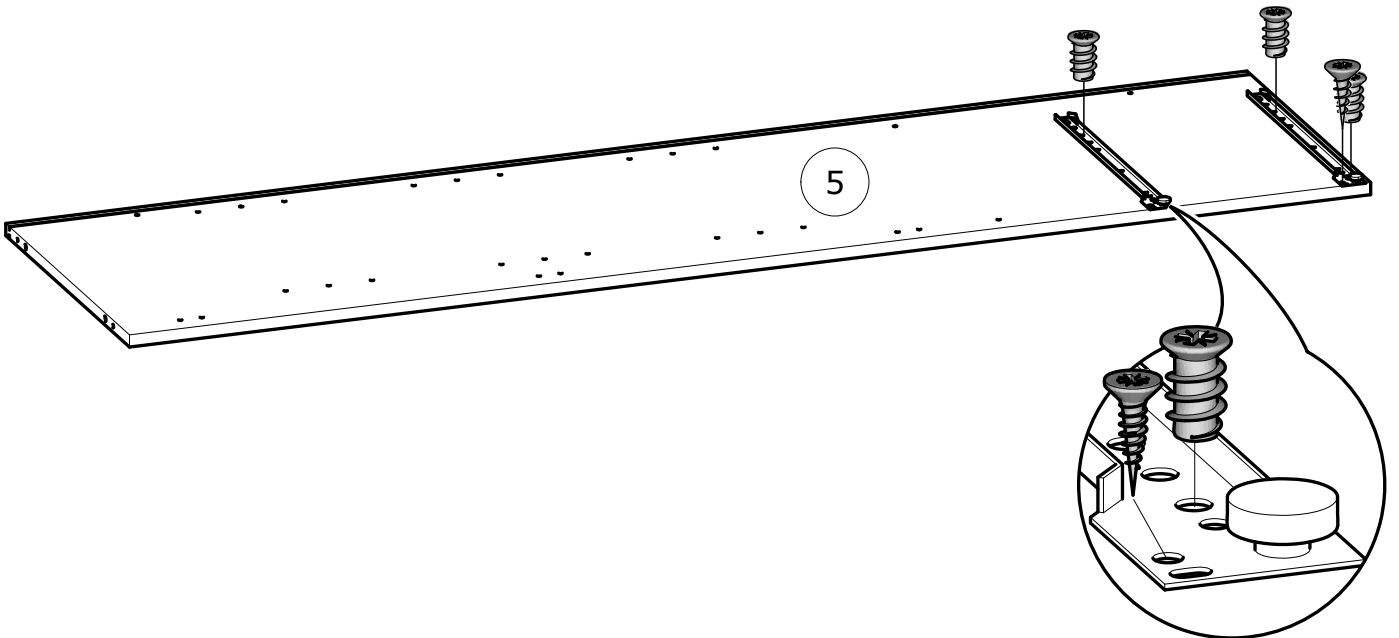
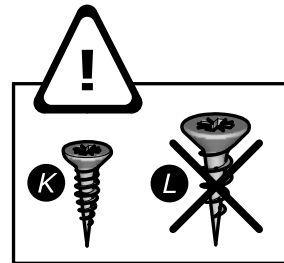

C x2

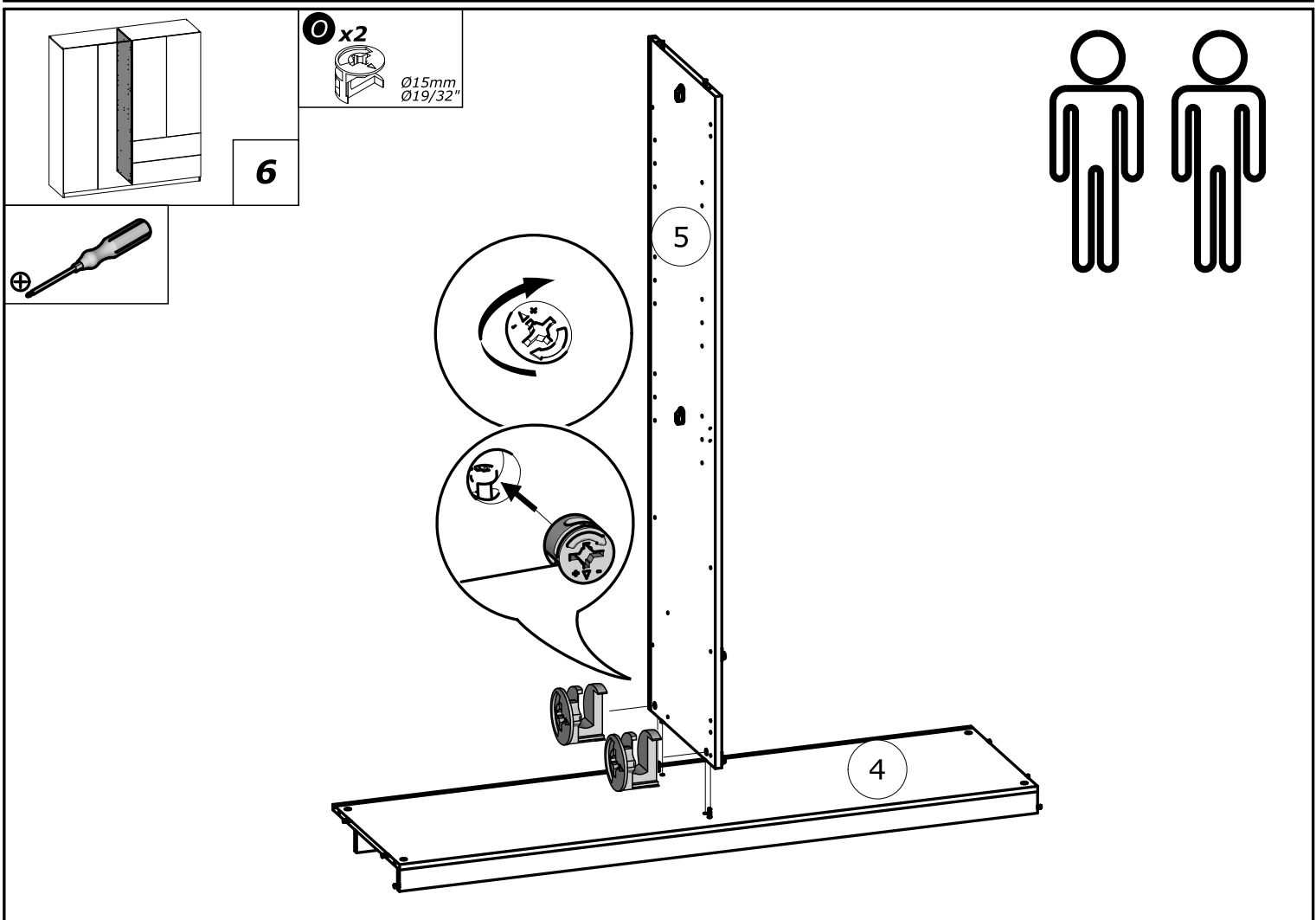
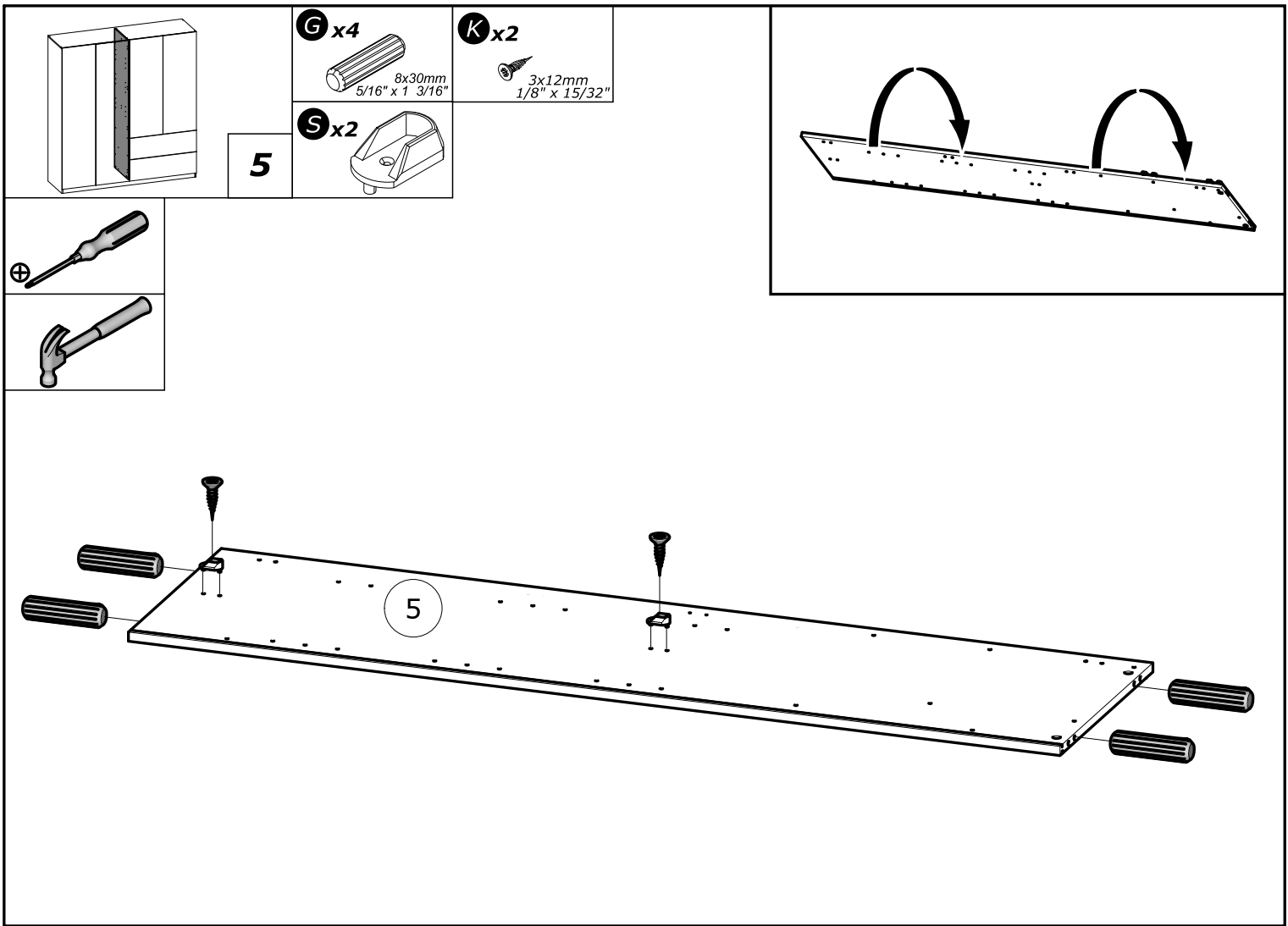

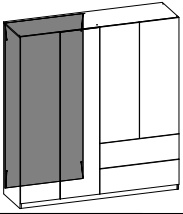





7

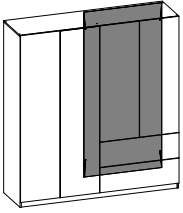
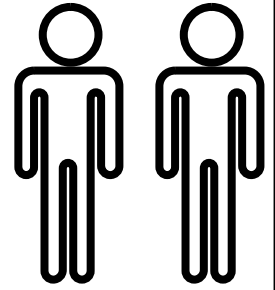
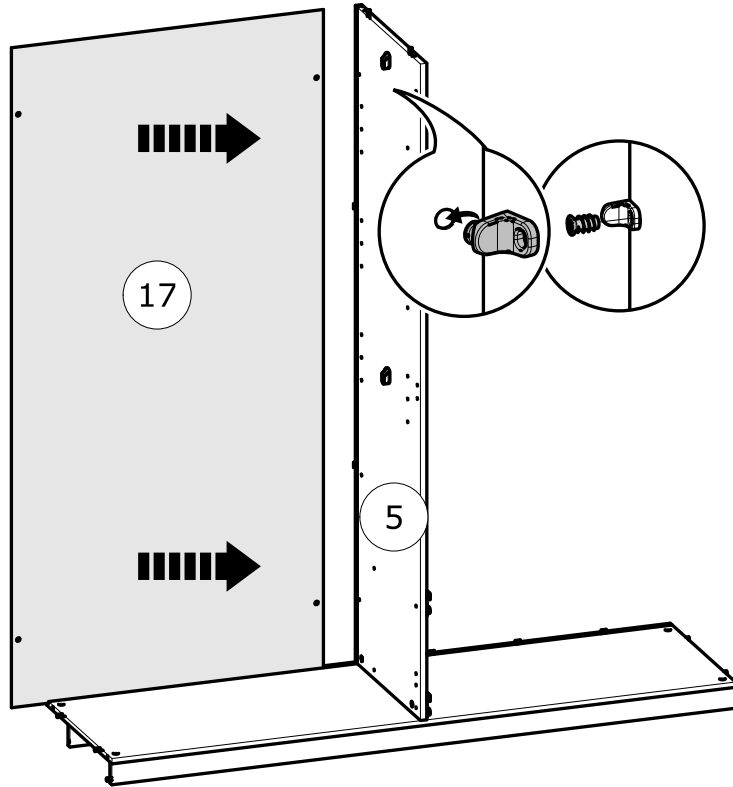
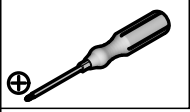



P x2  **J** x2 
6.3x9mm
1/4" x 11/32"

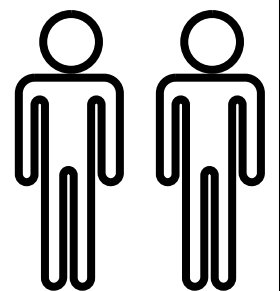
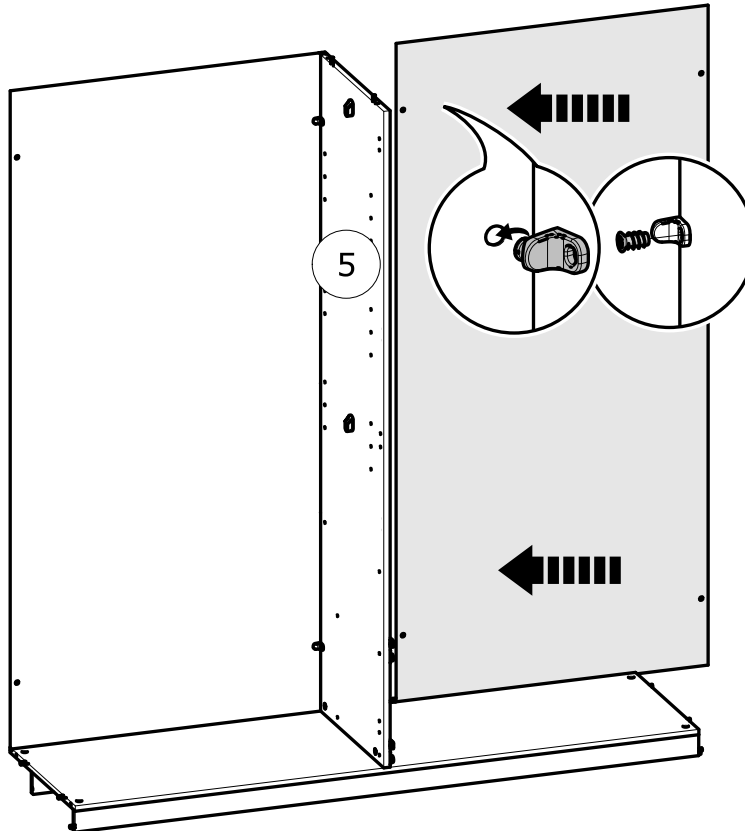
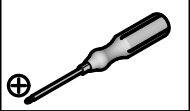

8

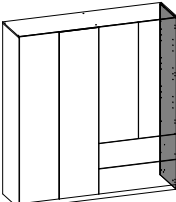
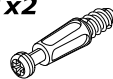

P x2  **J** x2 
6.3x9mm
1/4" x 11/32"

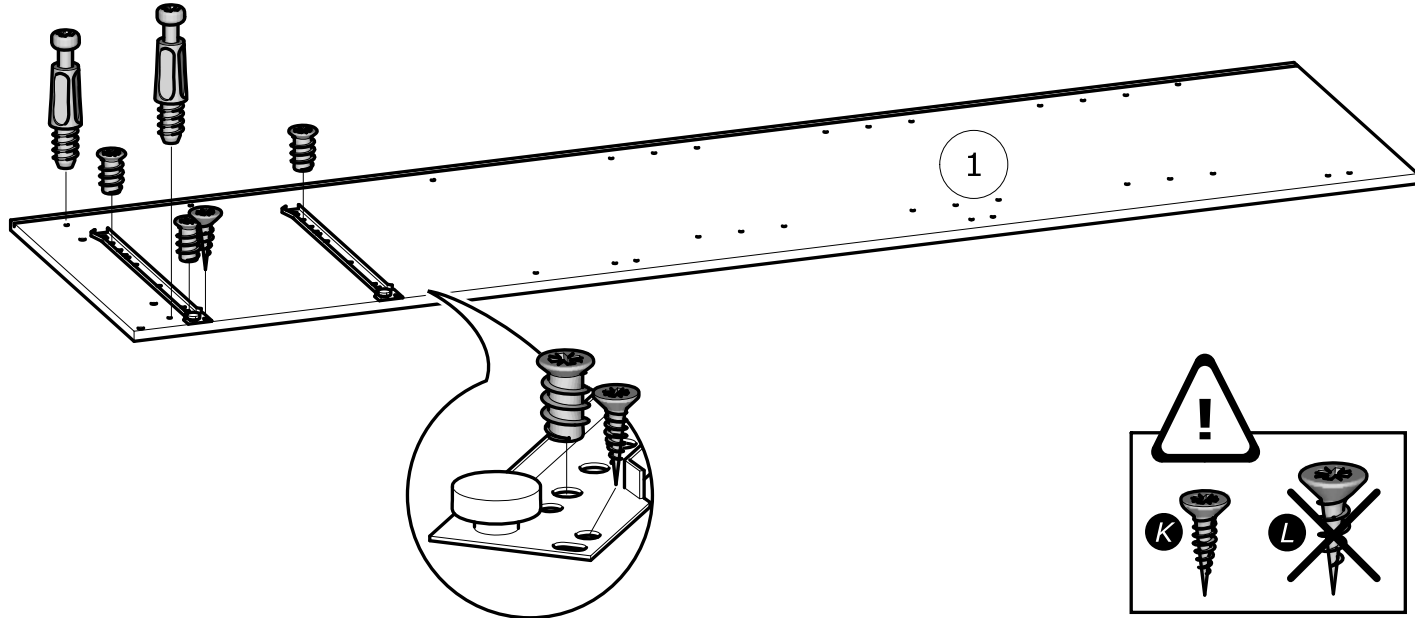
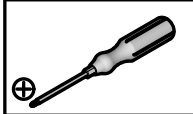

	N x2 	J x4  6.3x9mm 1/4" x 11/32"
	K x2  3x12mm 1/8" x 15/32"	G x2 

9

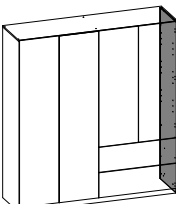
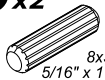

	G x2  8x30mm 5/16" x 1 3/16"	U x1 
--	---	--

10

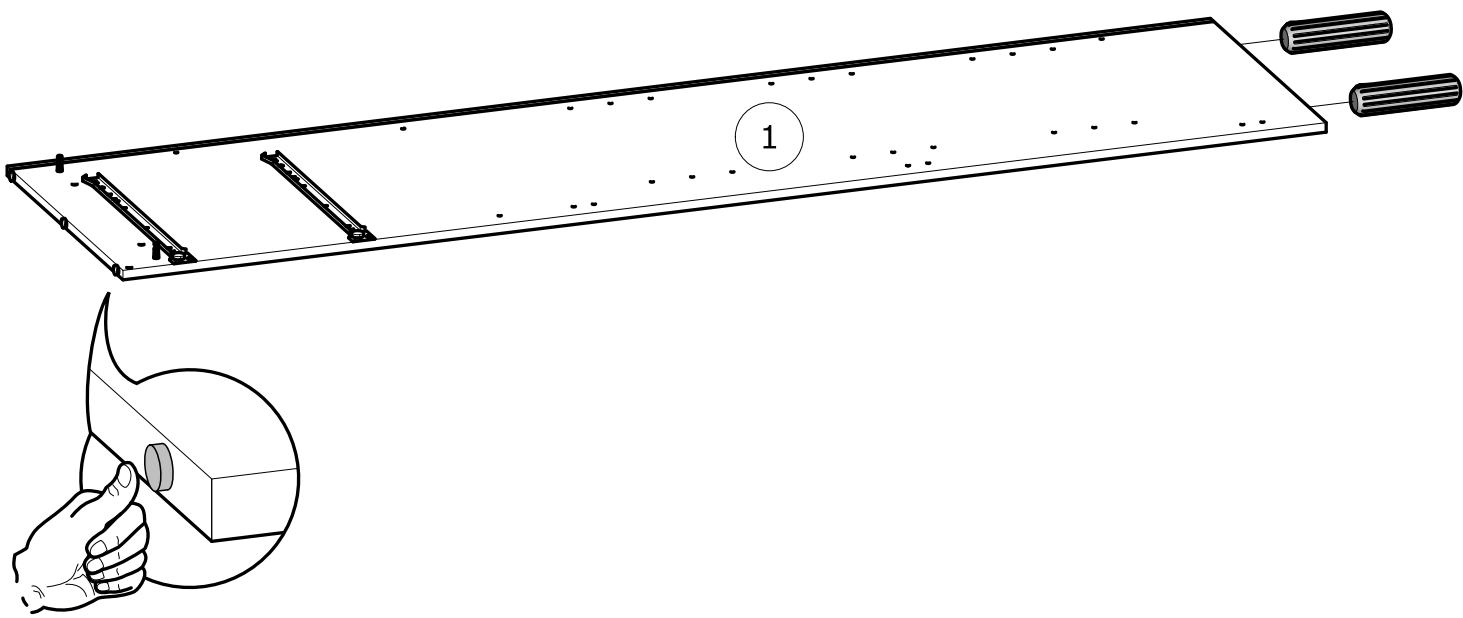
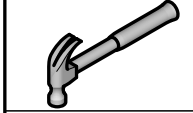

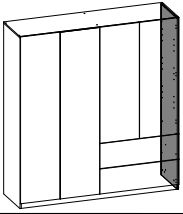

11

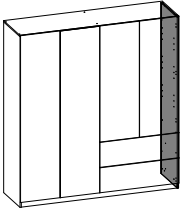
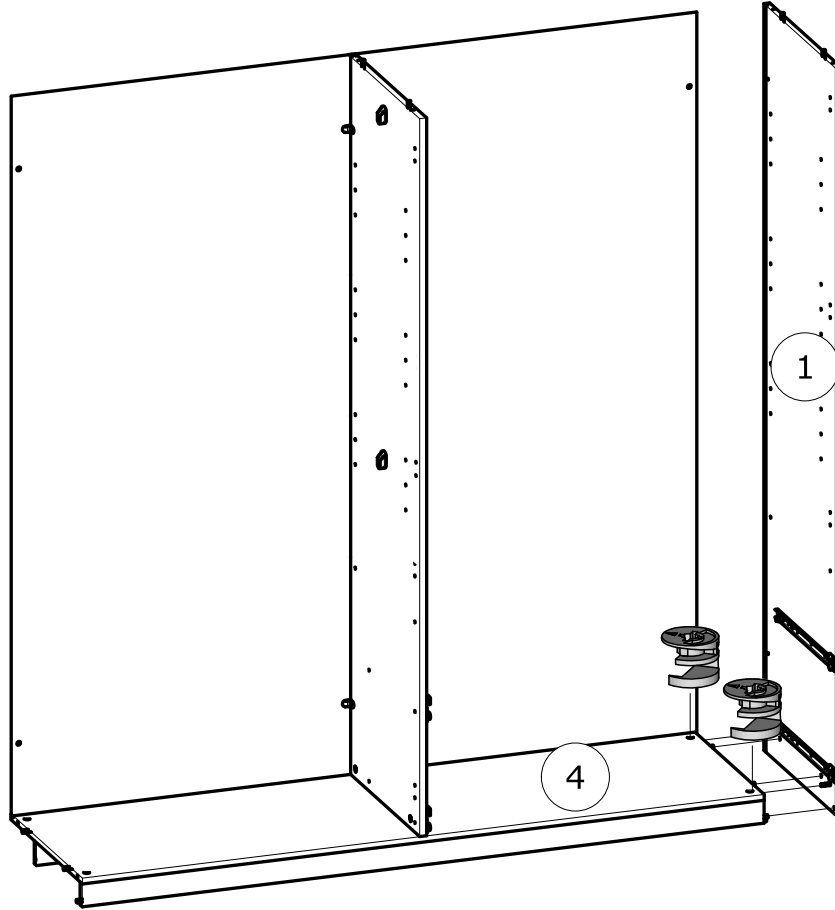
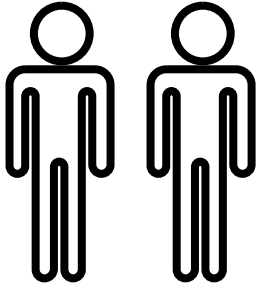
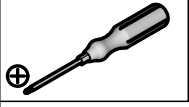
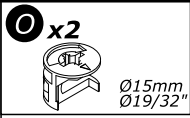

12

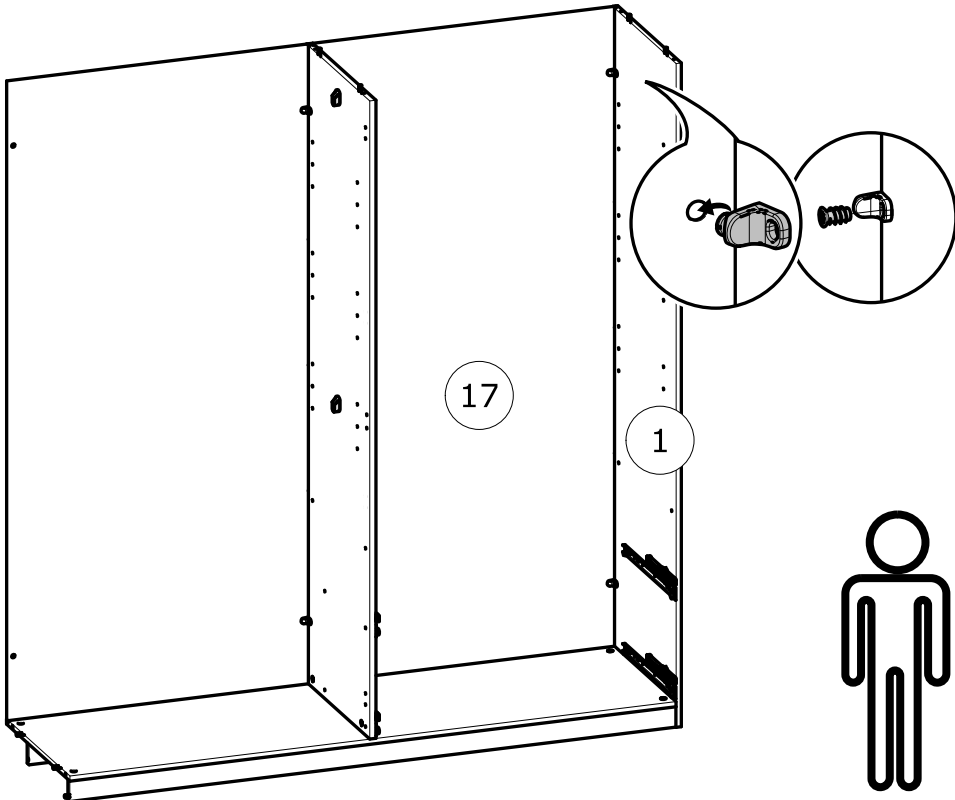
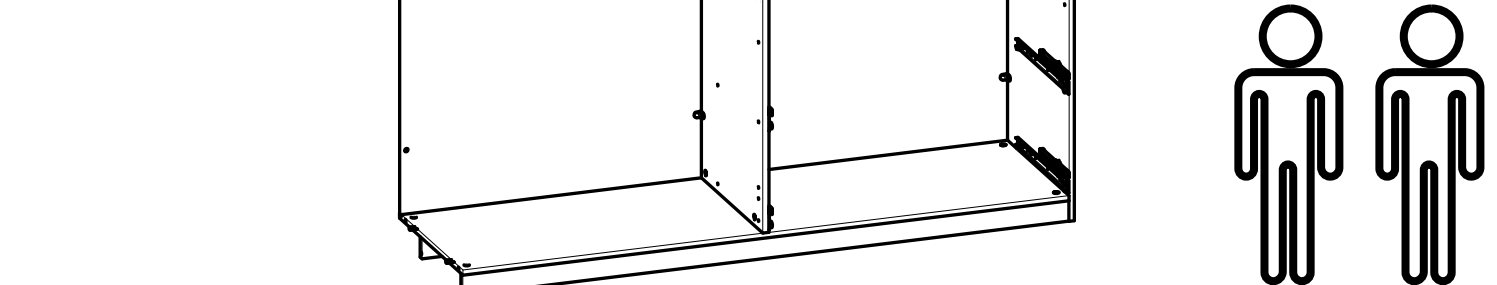
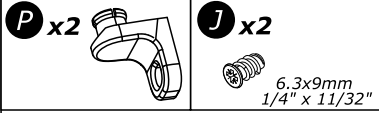

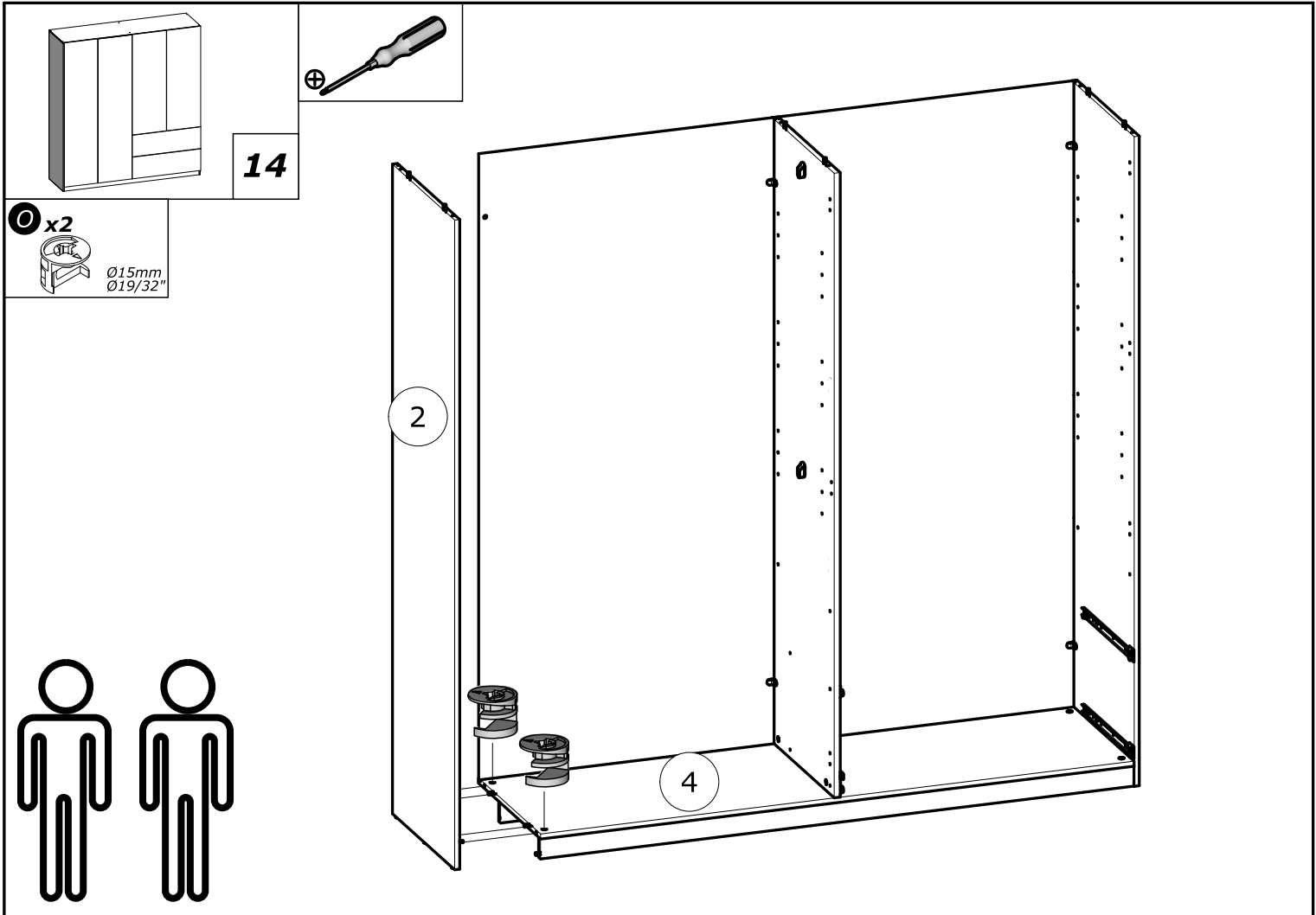
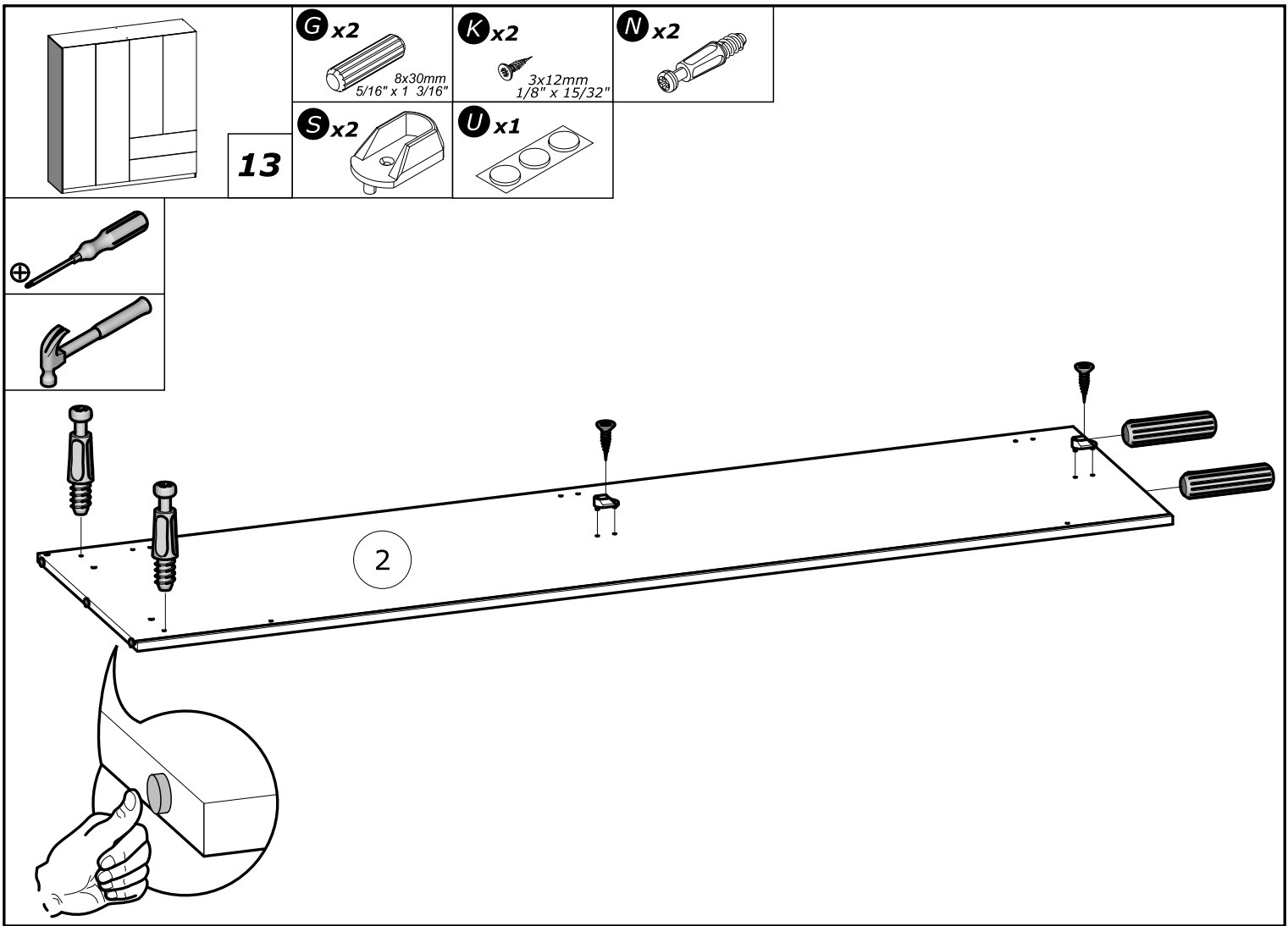

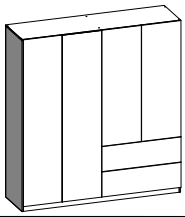

15

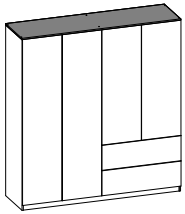
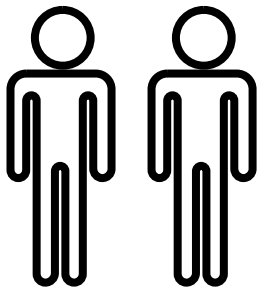
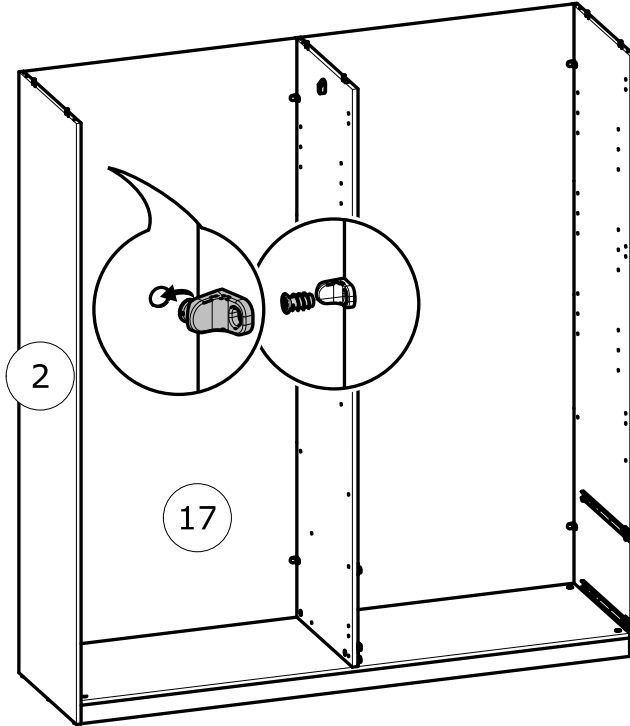
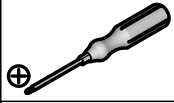
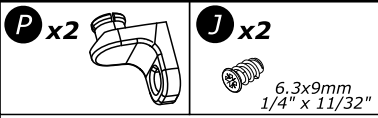

16

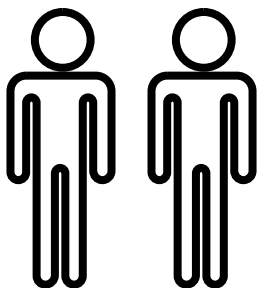
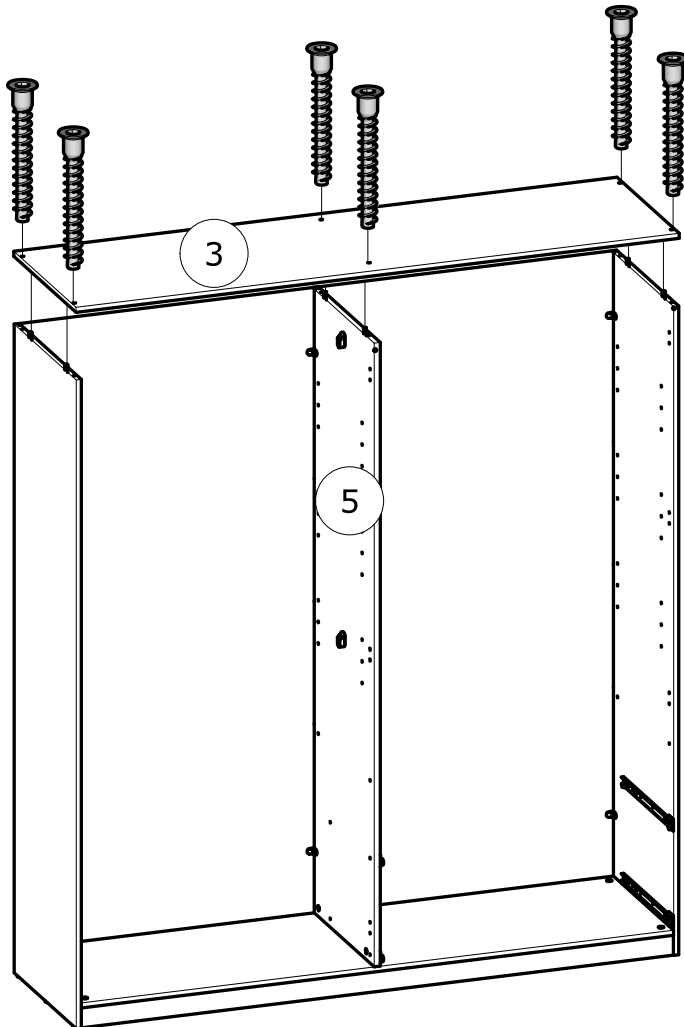
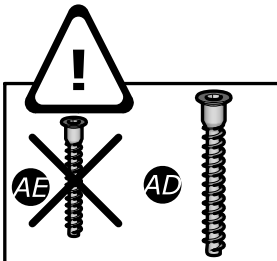
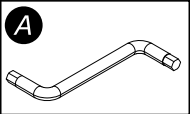
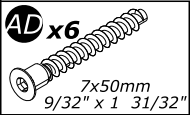

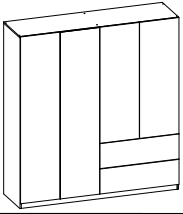

17

B x32

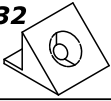

I x32

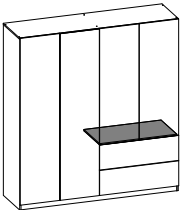
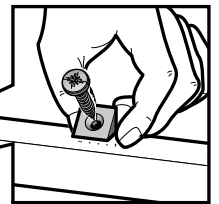
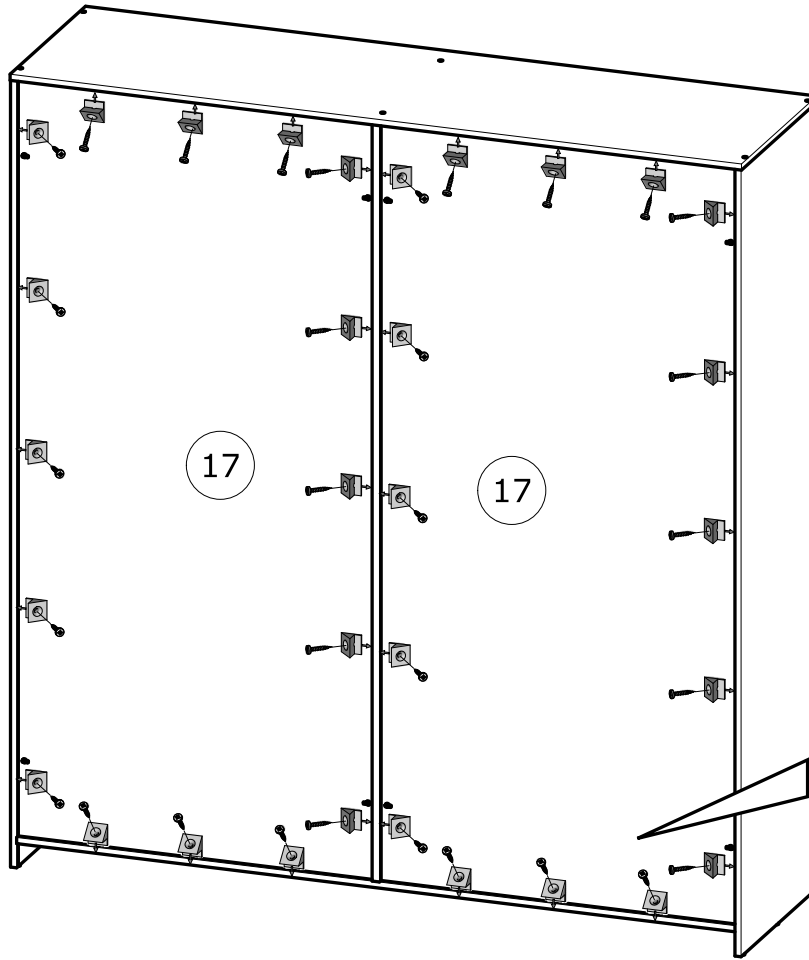
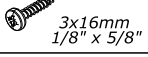

18

E x4

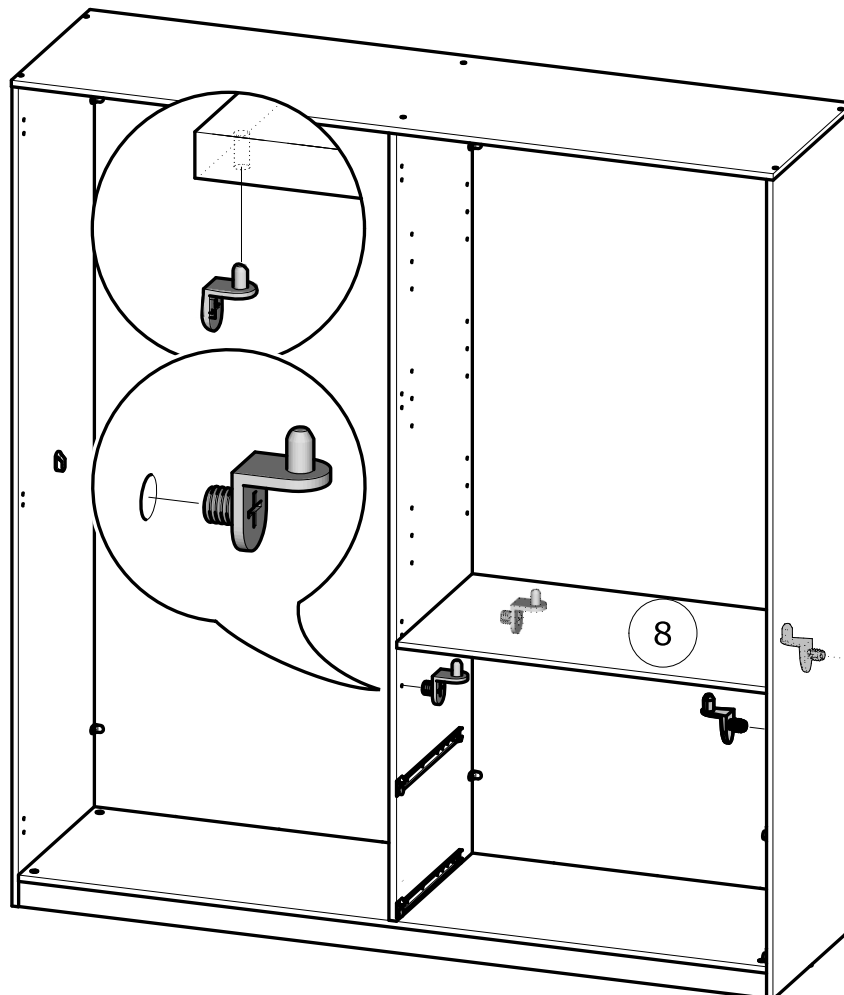

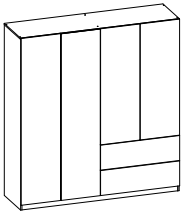

19

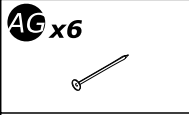

AG x6

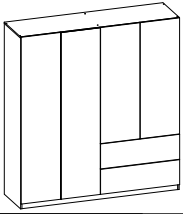
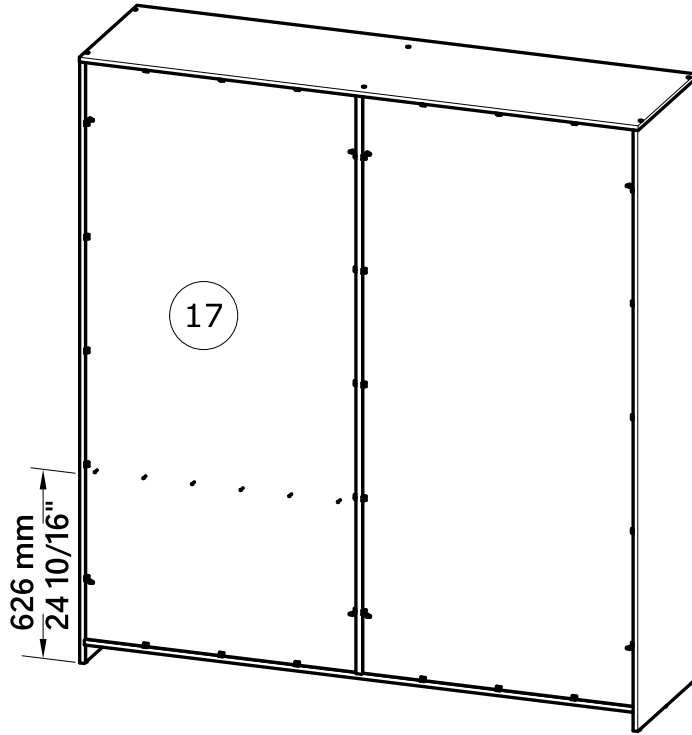
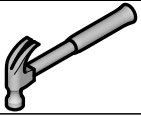

20



AC x2

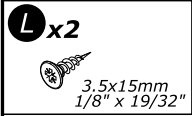

L x2

3.5x15mm
1/8" x 19/32"

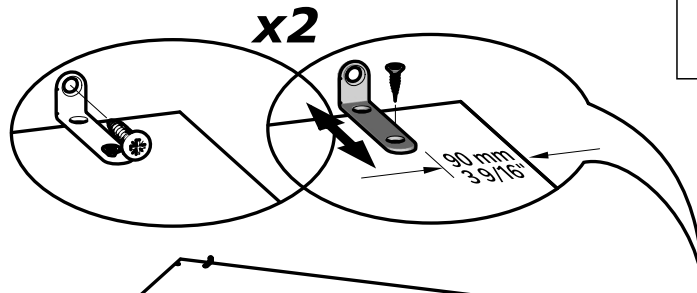

x2

90 mm
3 9/16"

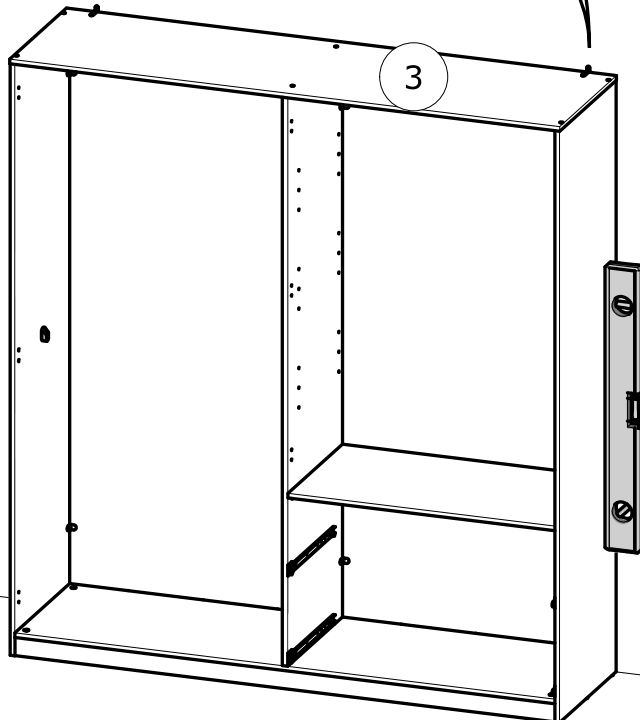
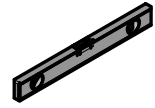

3

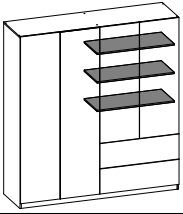

21

E x12

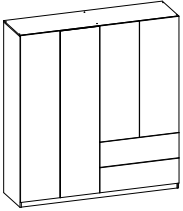
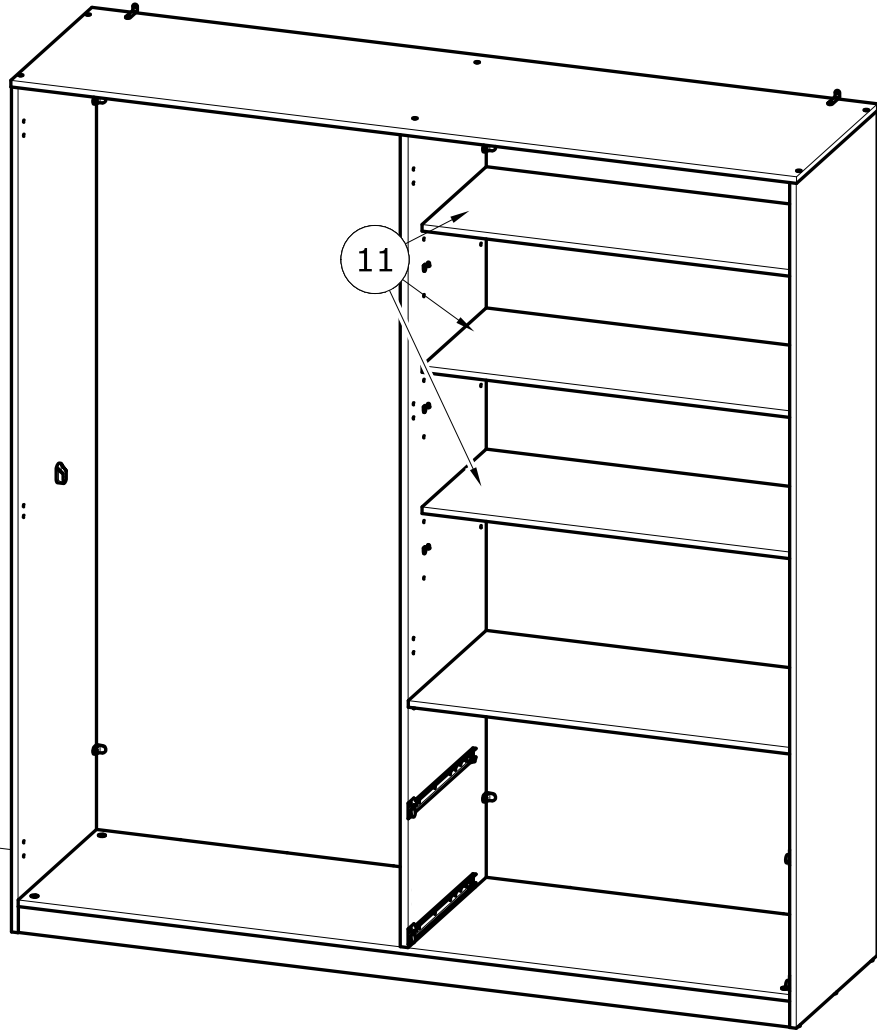
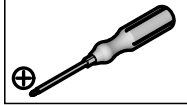

22

M x2

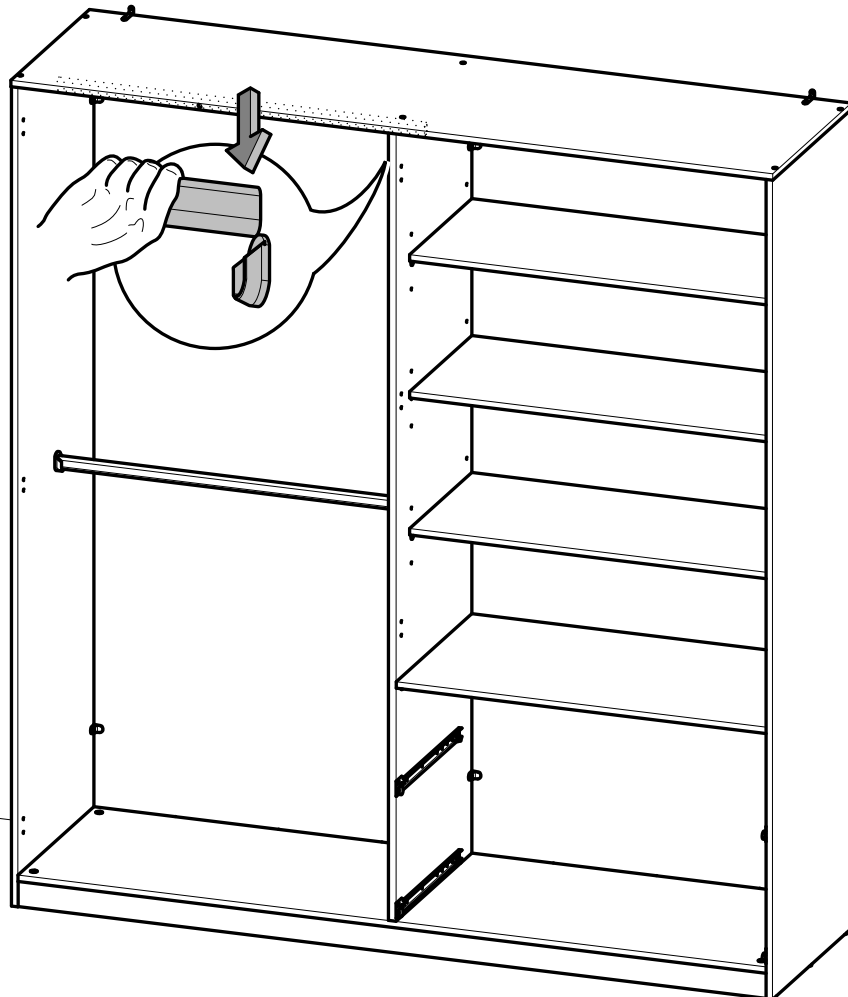
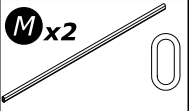

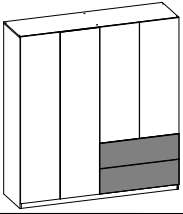

23

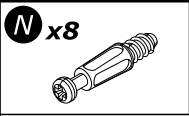

x2

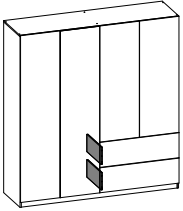
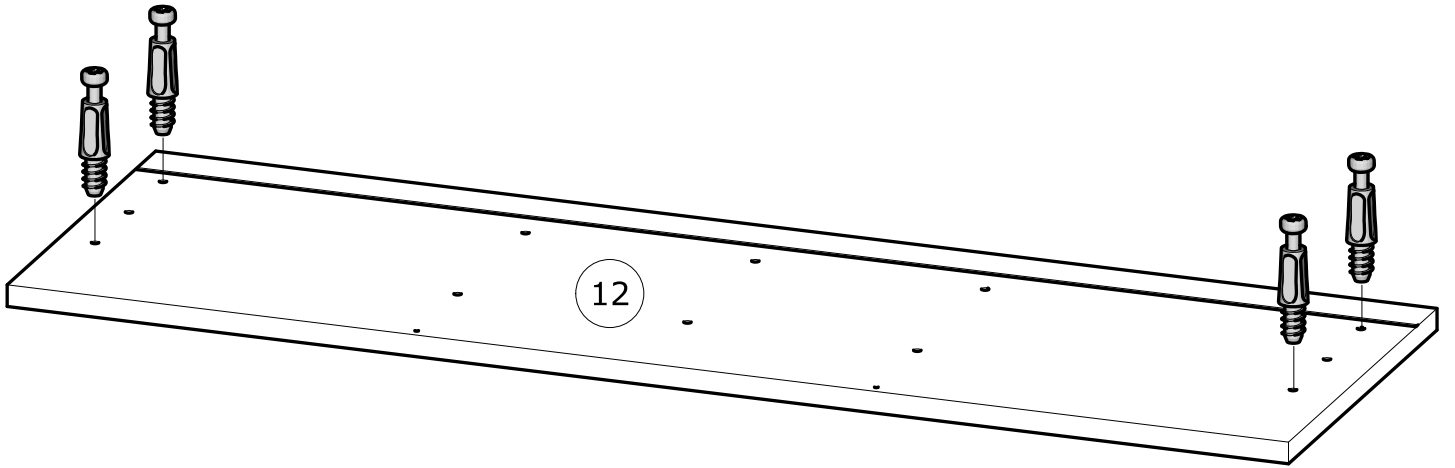
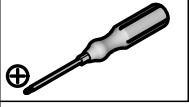

24

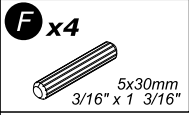

x2

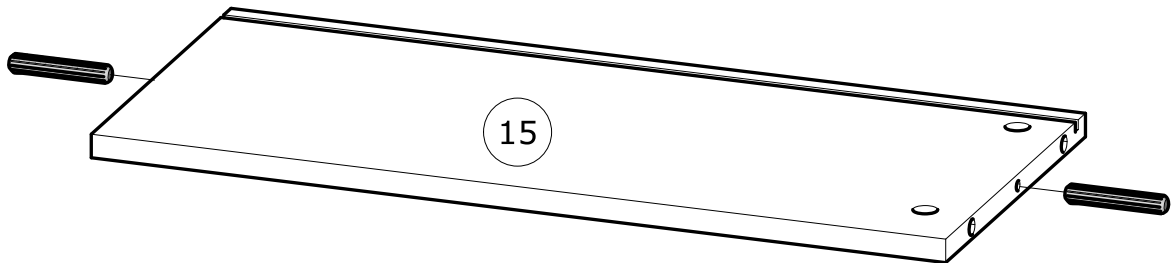
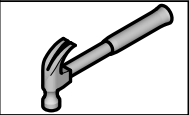

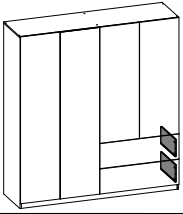

25

F x4
5x30mm
3/16" x 1 3/16"

x2

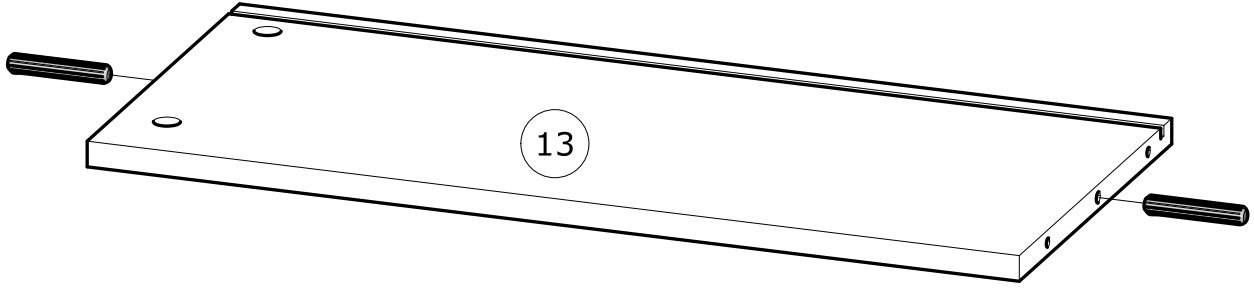
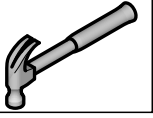

13

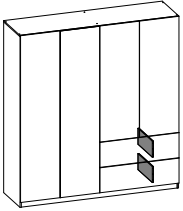

26

F x4
5x30mm
3/16" x 1 3/16"

x2

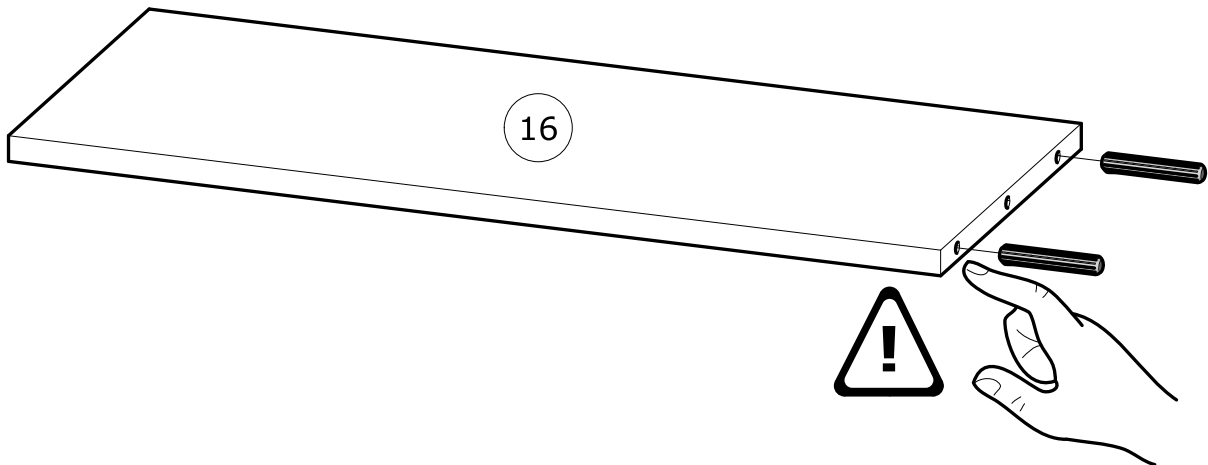
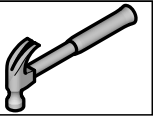

16

x2

R x8
Ø12mm
Ø15/32"

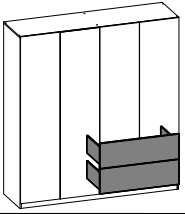

27

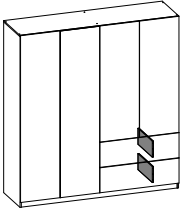
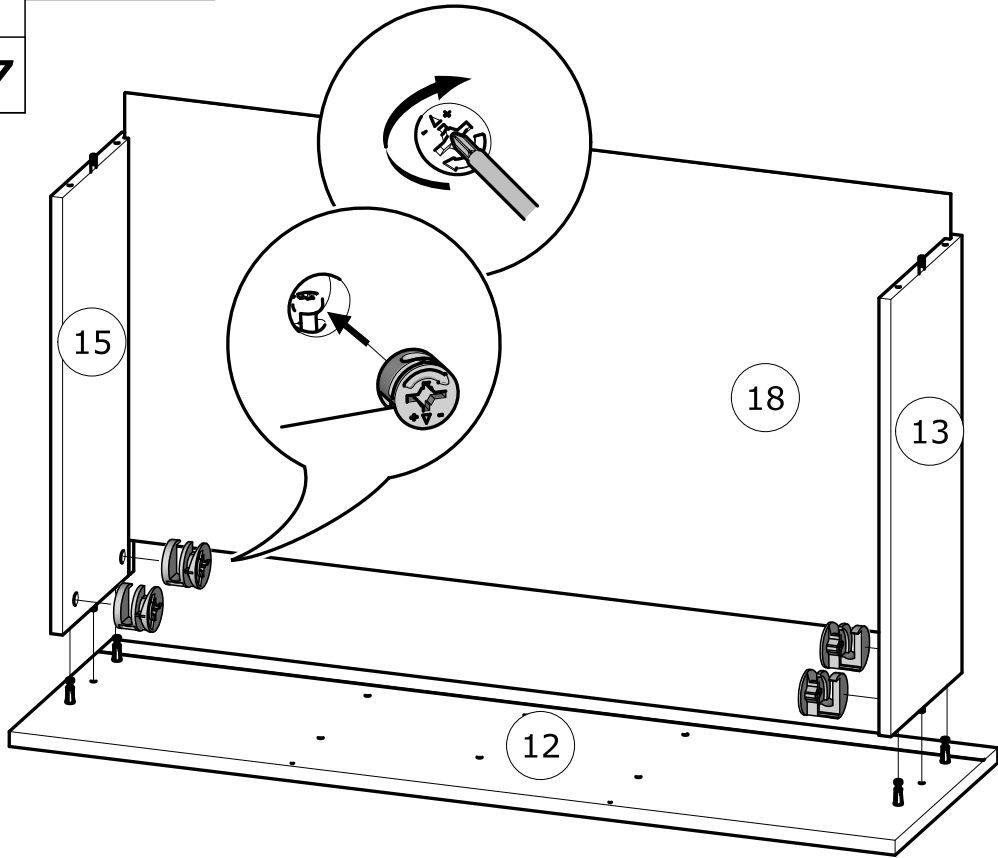
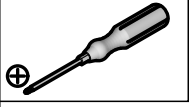

28

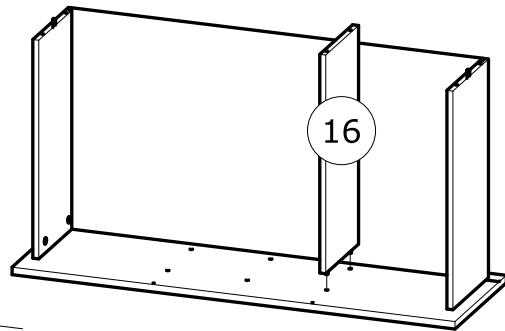

OU/OR

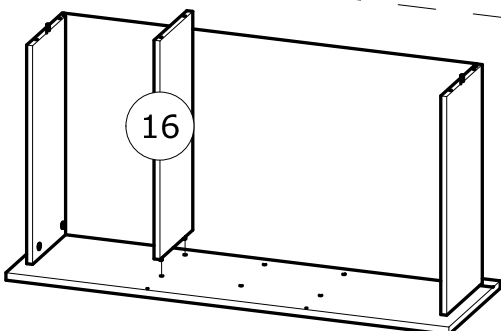
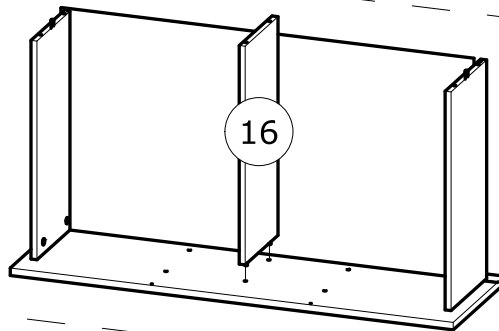

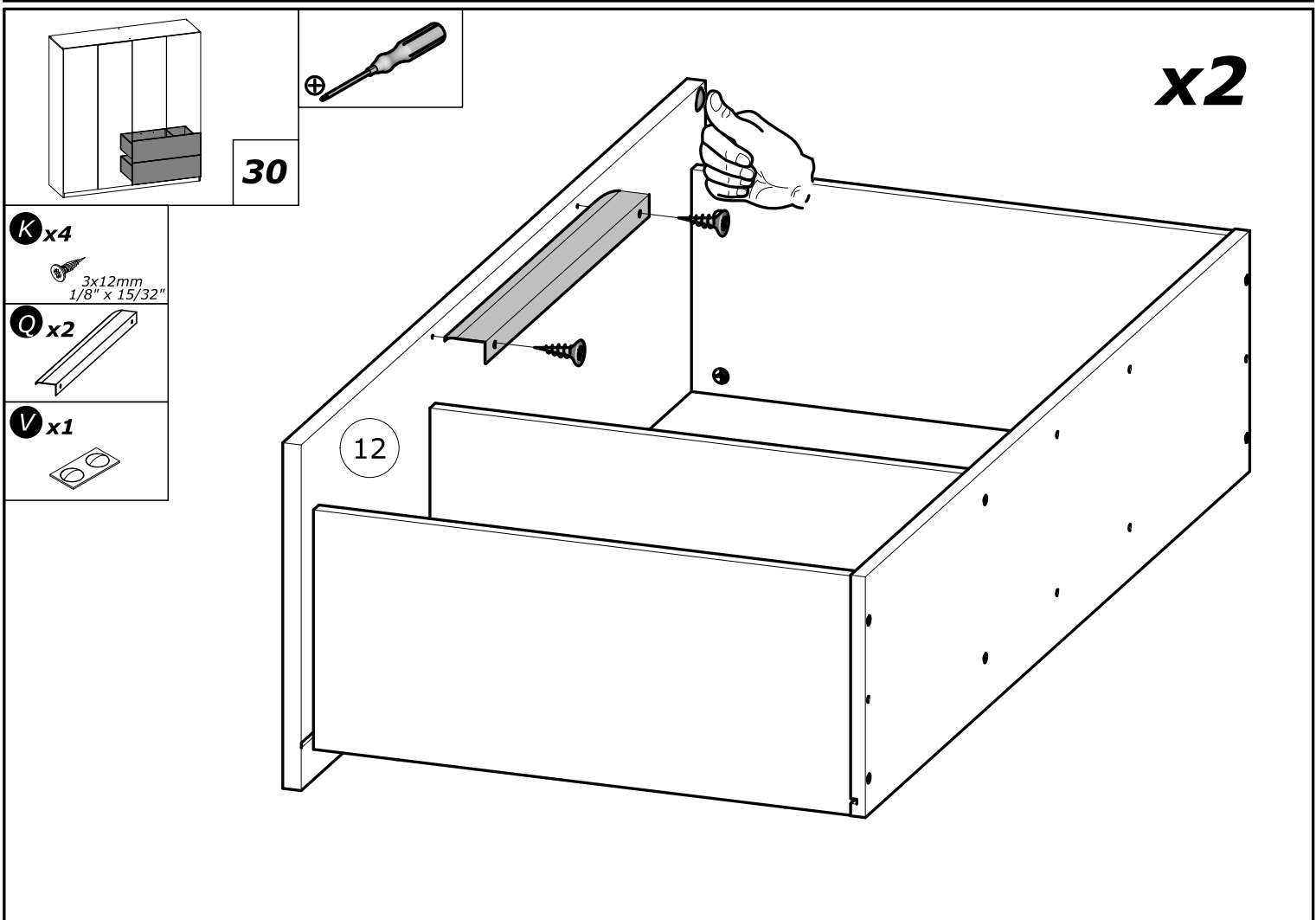
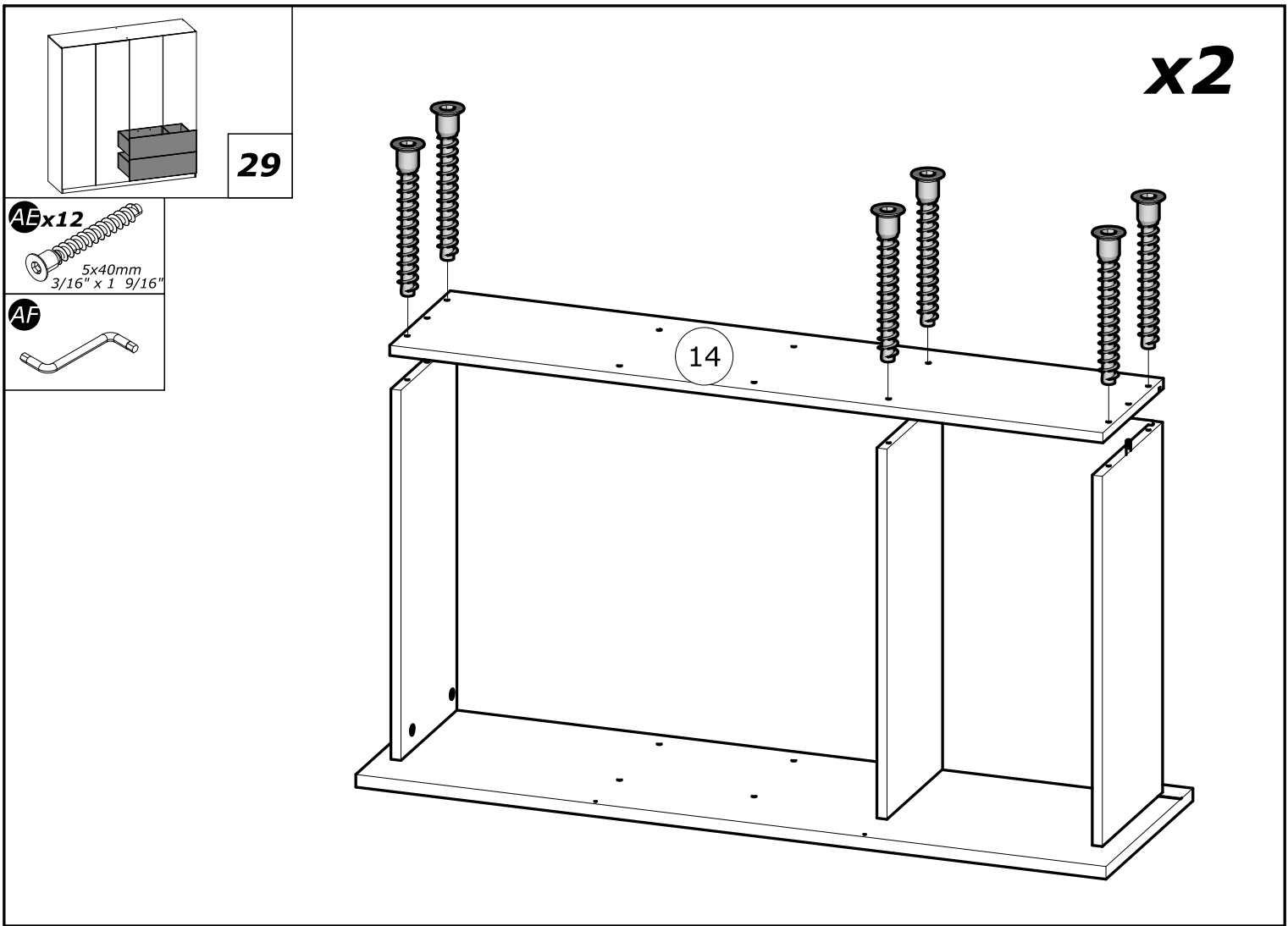

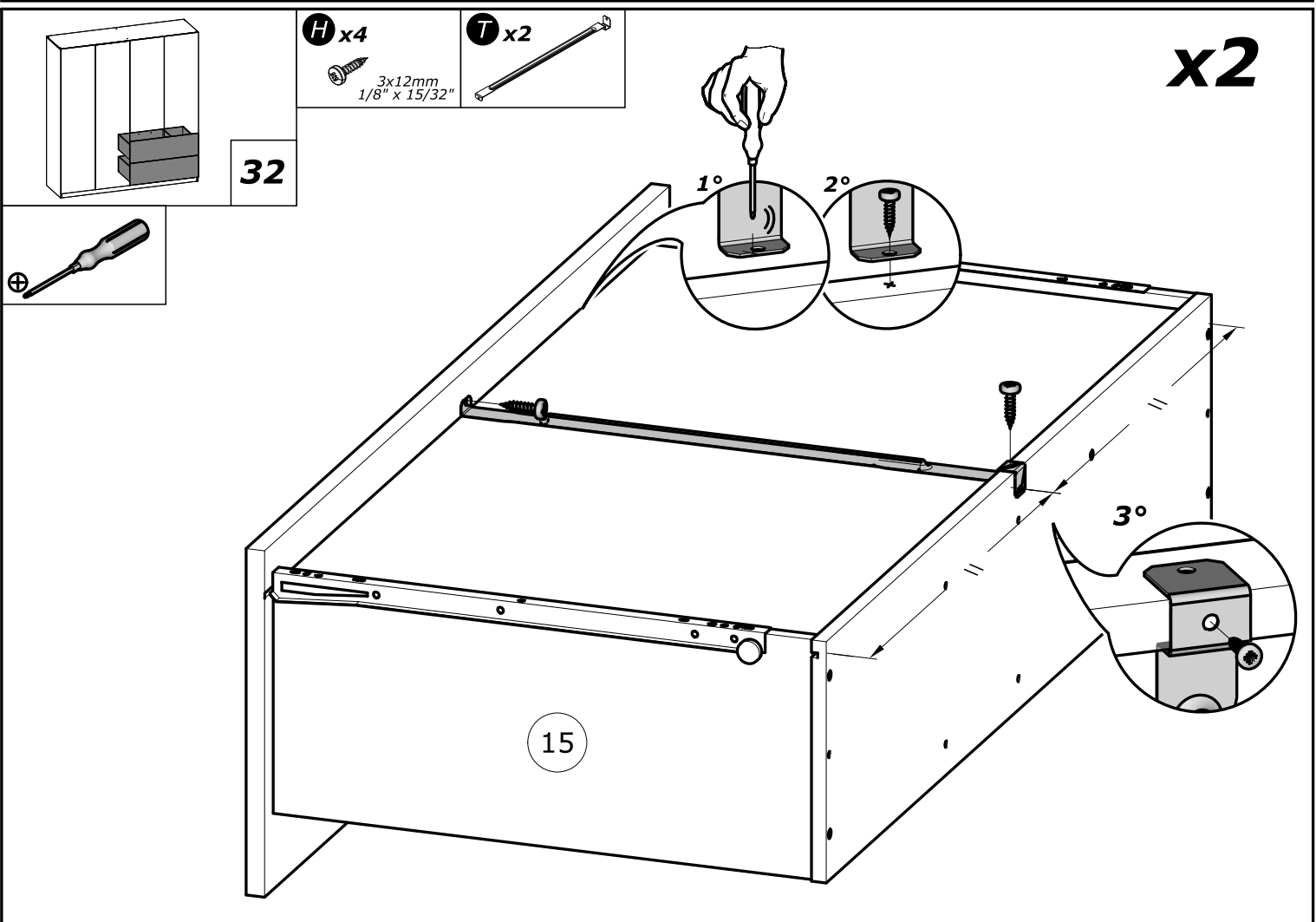
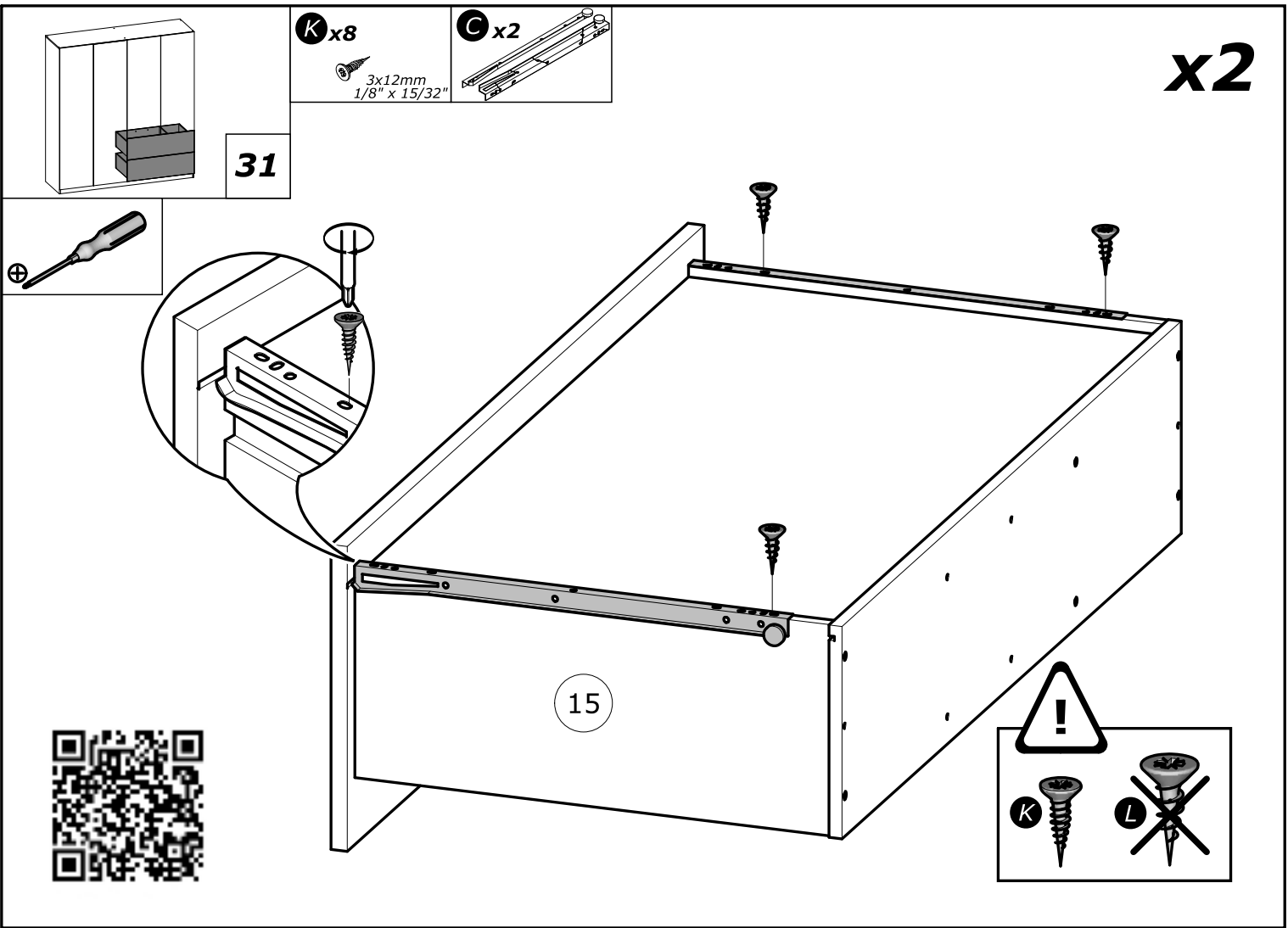

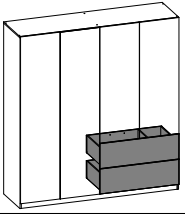

33

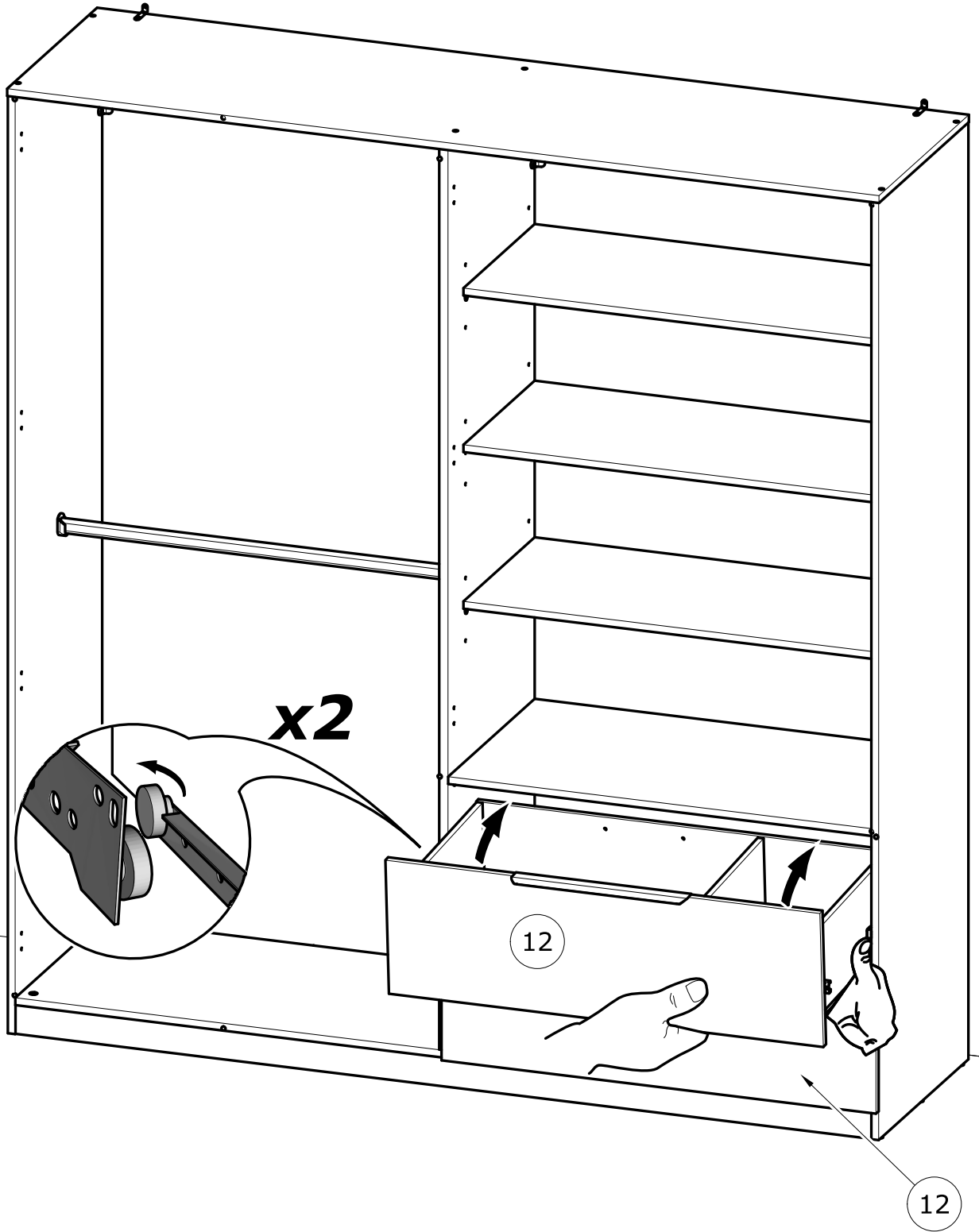

x2

12

12

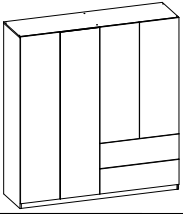

34

X x6

H=2mm
H=1/16"

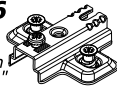

Y x6

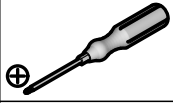

x6

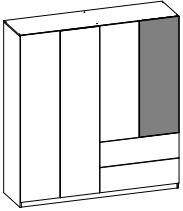
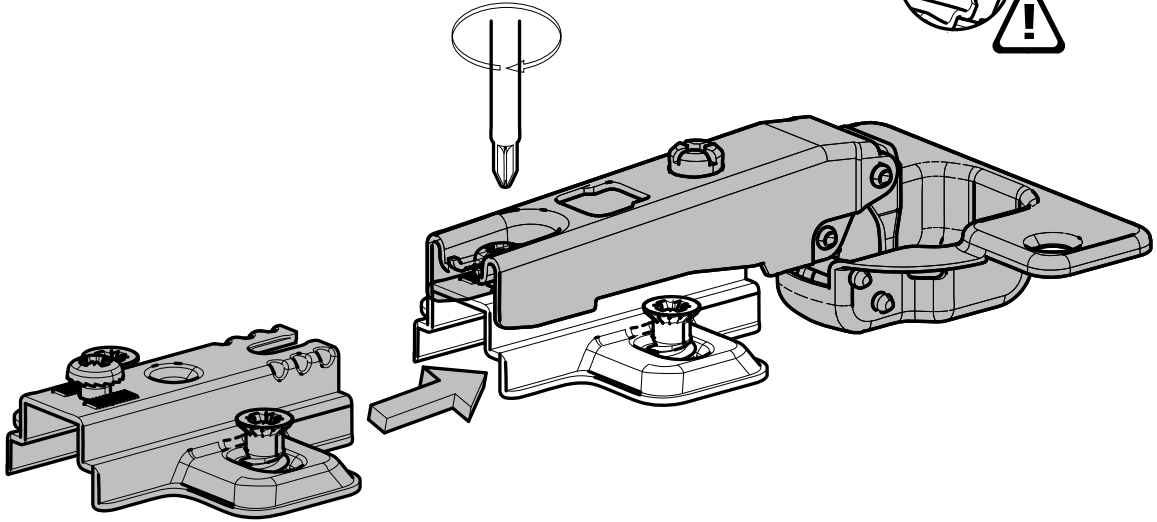
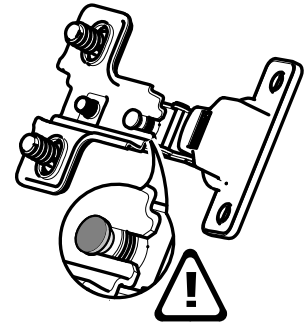

35

L x6



3.5x15mm
1/8" x 19/32"

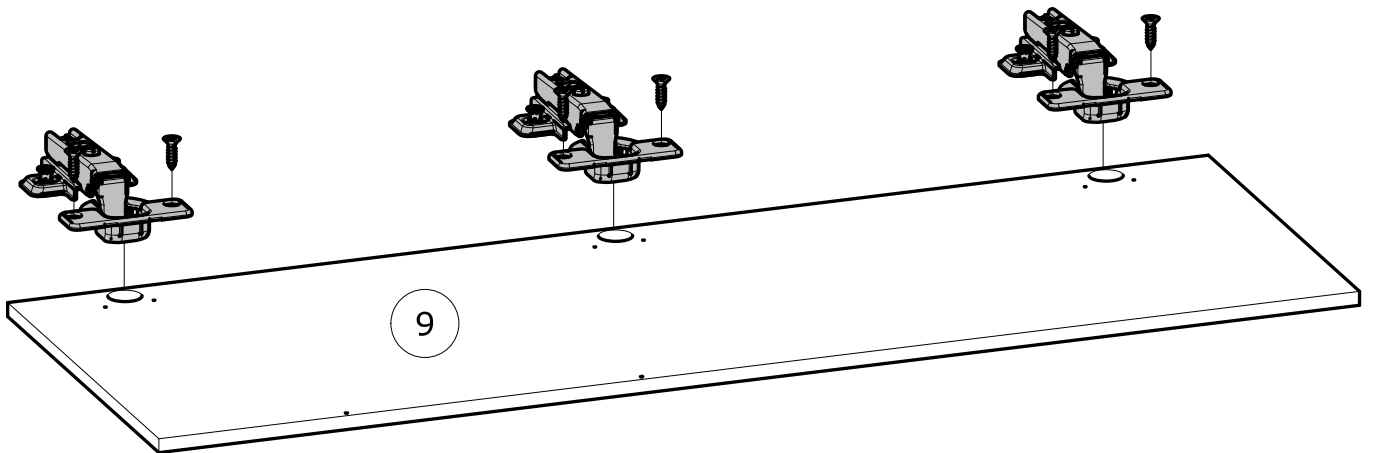

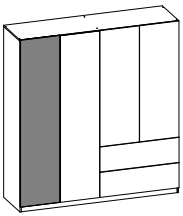

36

L x 6
3.5x15mm
1/8" x 19/32"

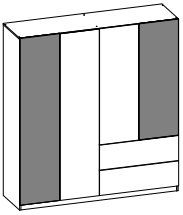
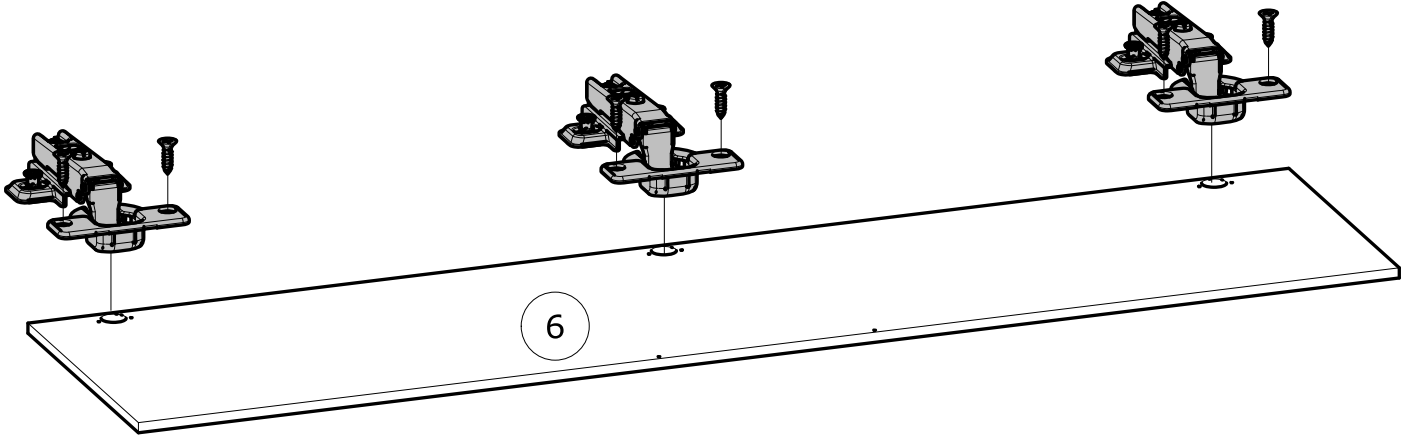

37

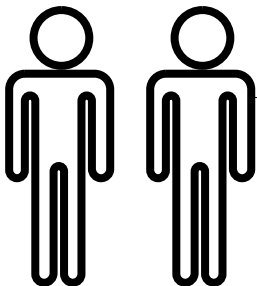
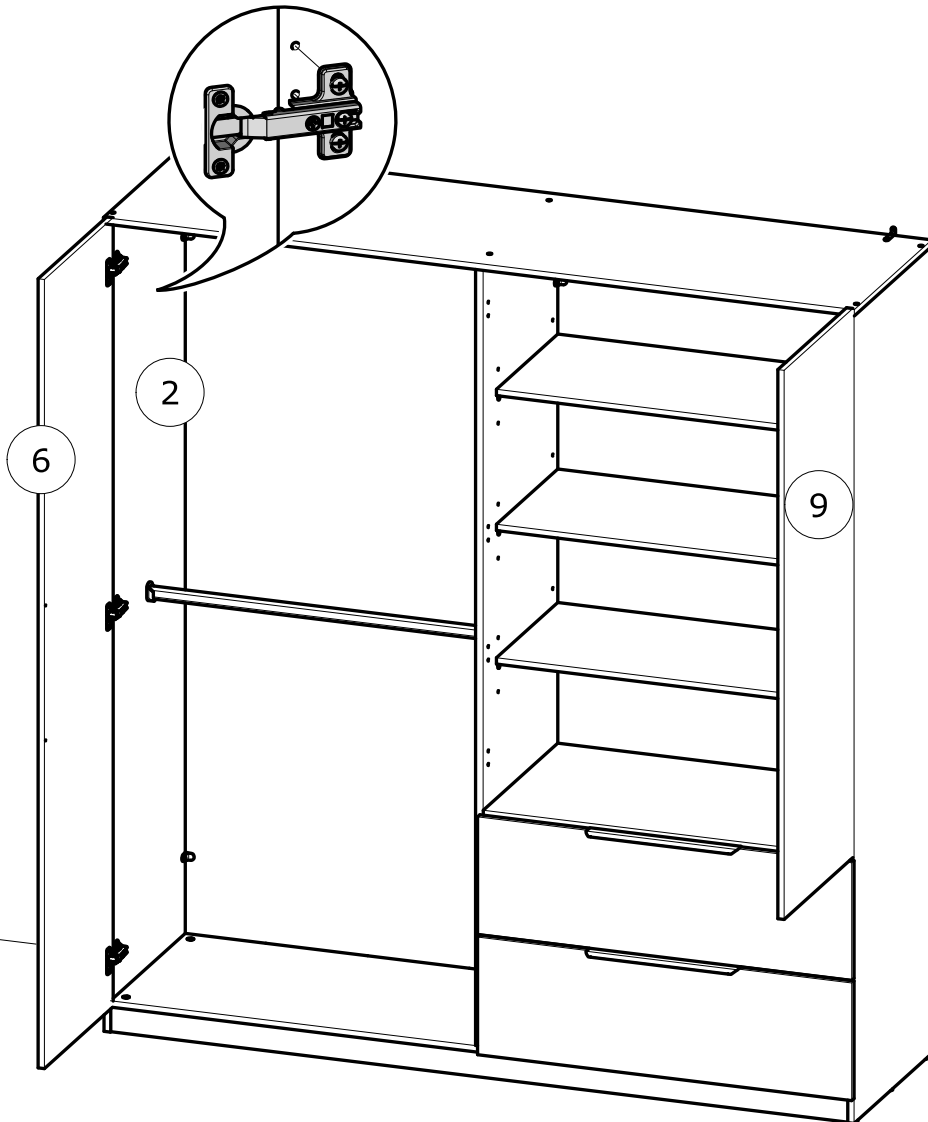

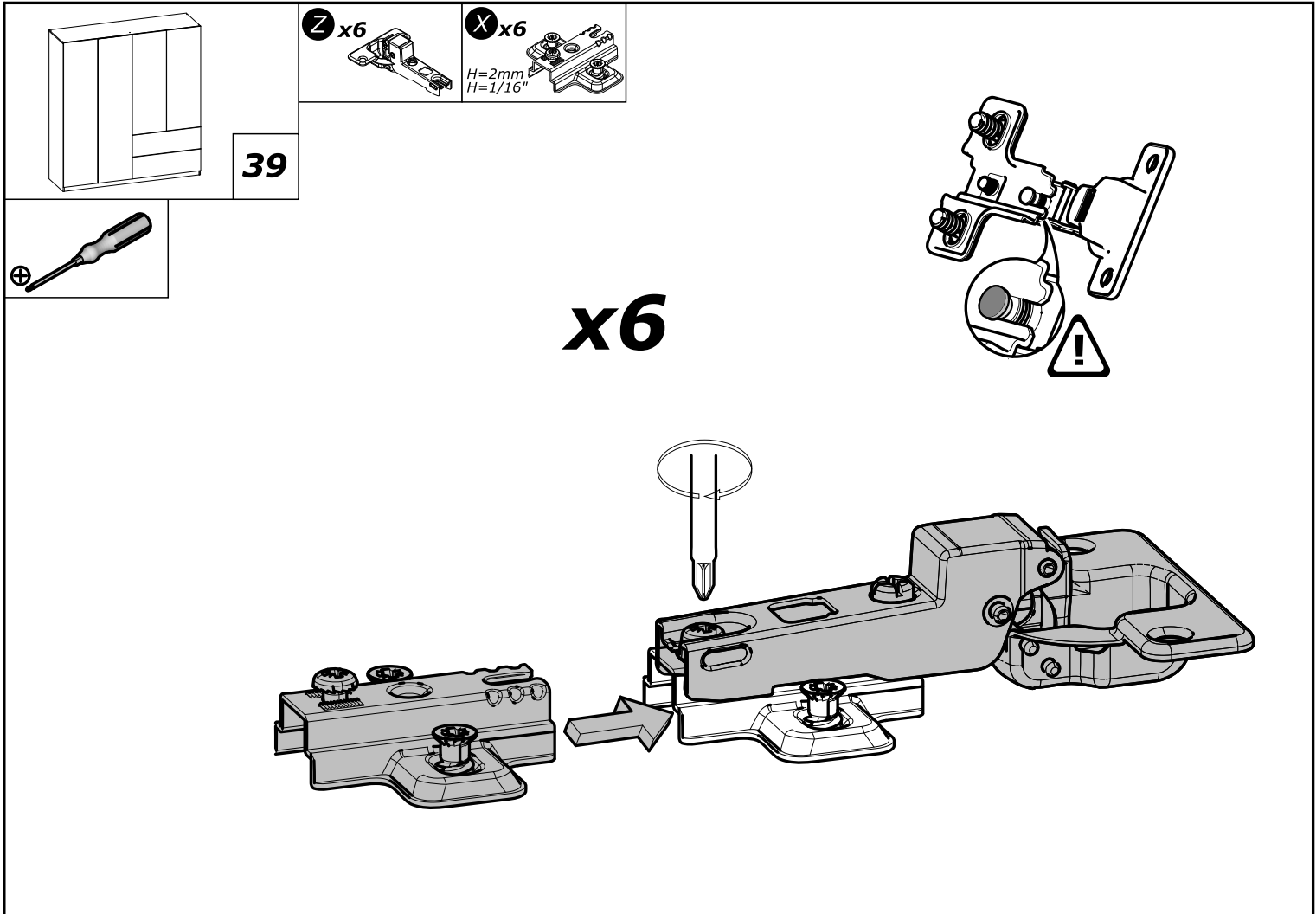
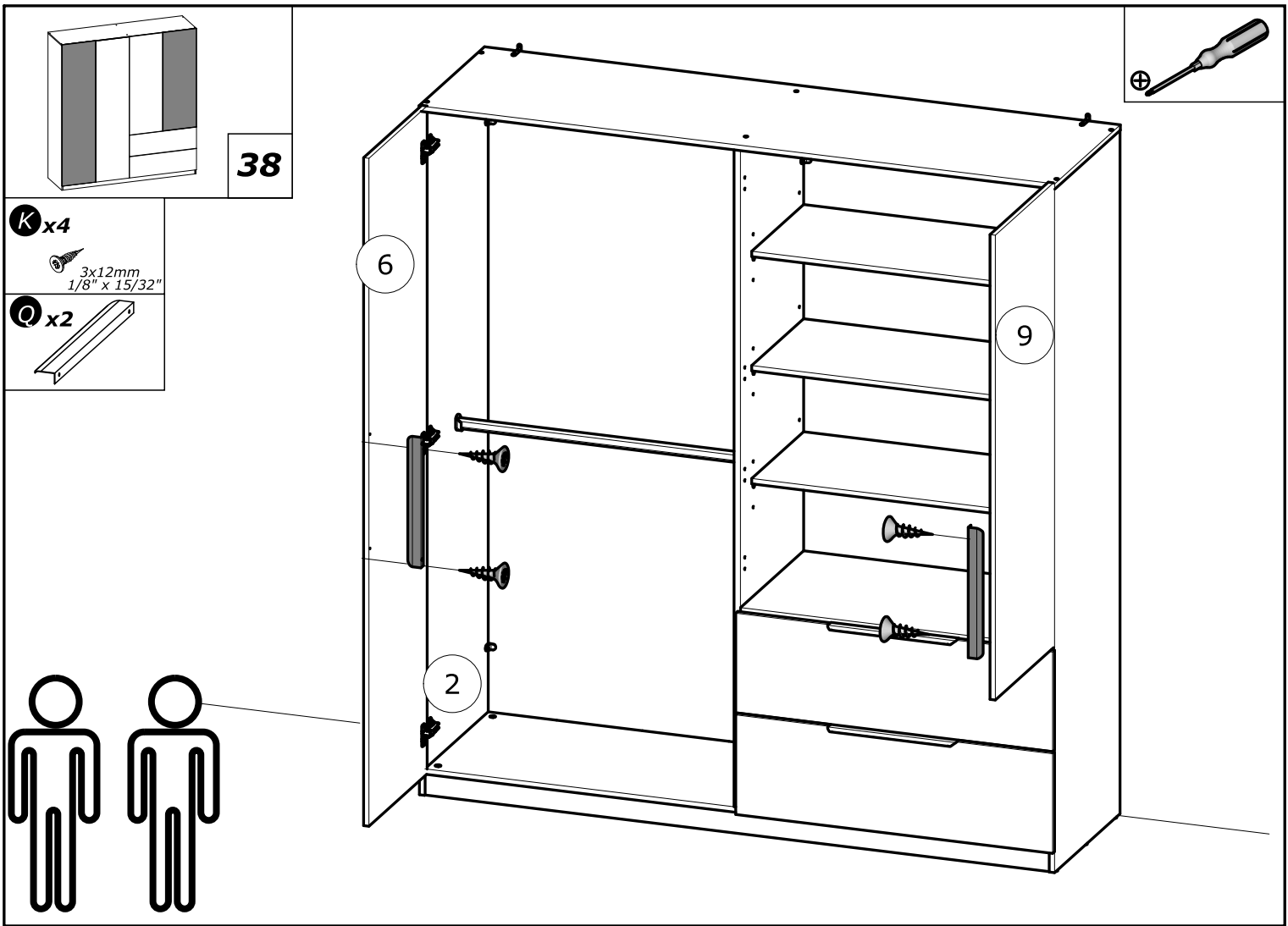

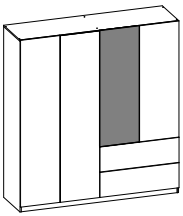

40

L x6
3.5x15mm
1/8" x 19/32"

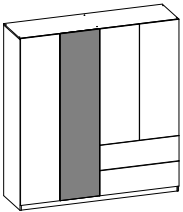
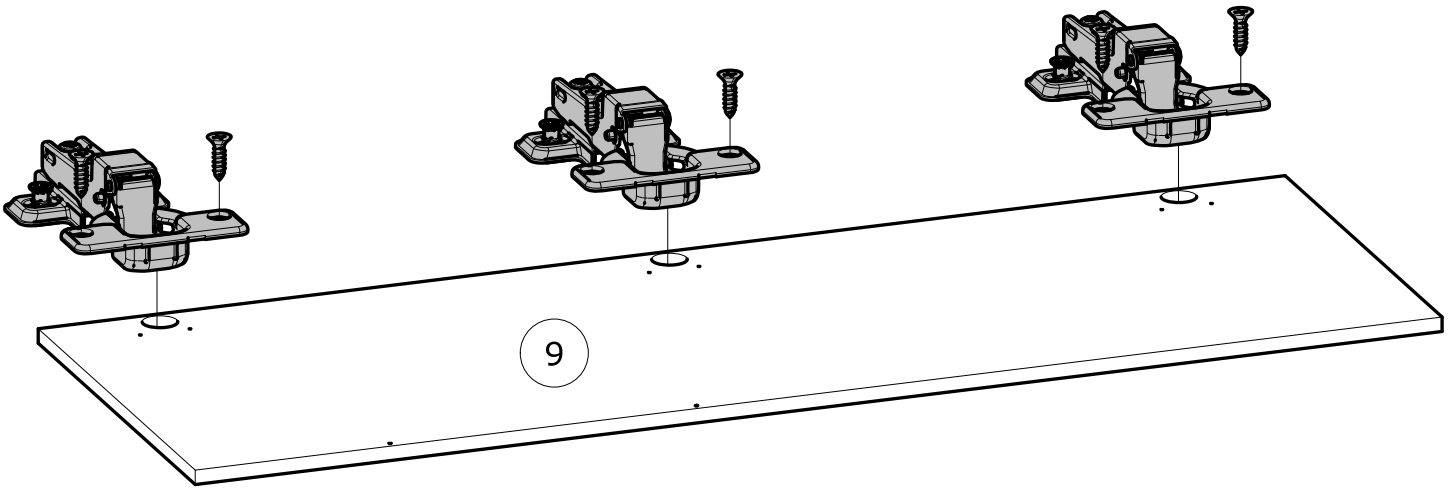

41

L x6
3.5x15mm
1/8" x 19/32"



FRAGILE

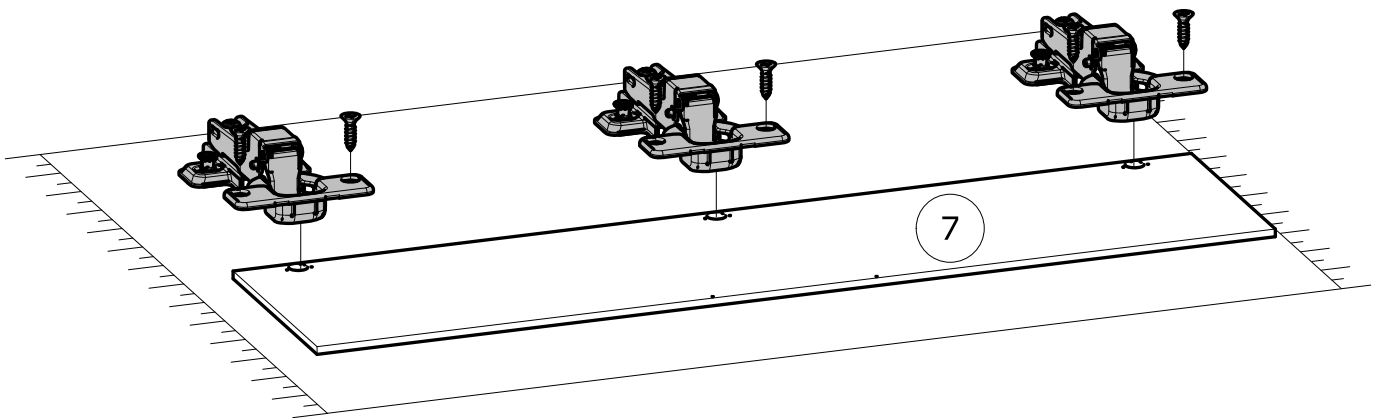
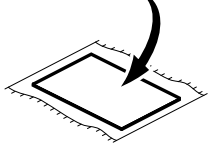

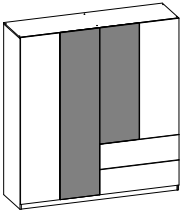

42



V x2

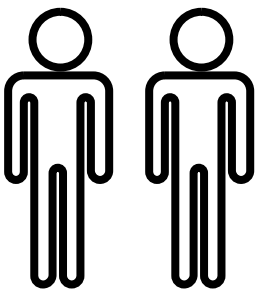
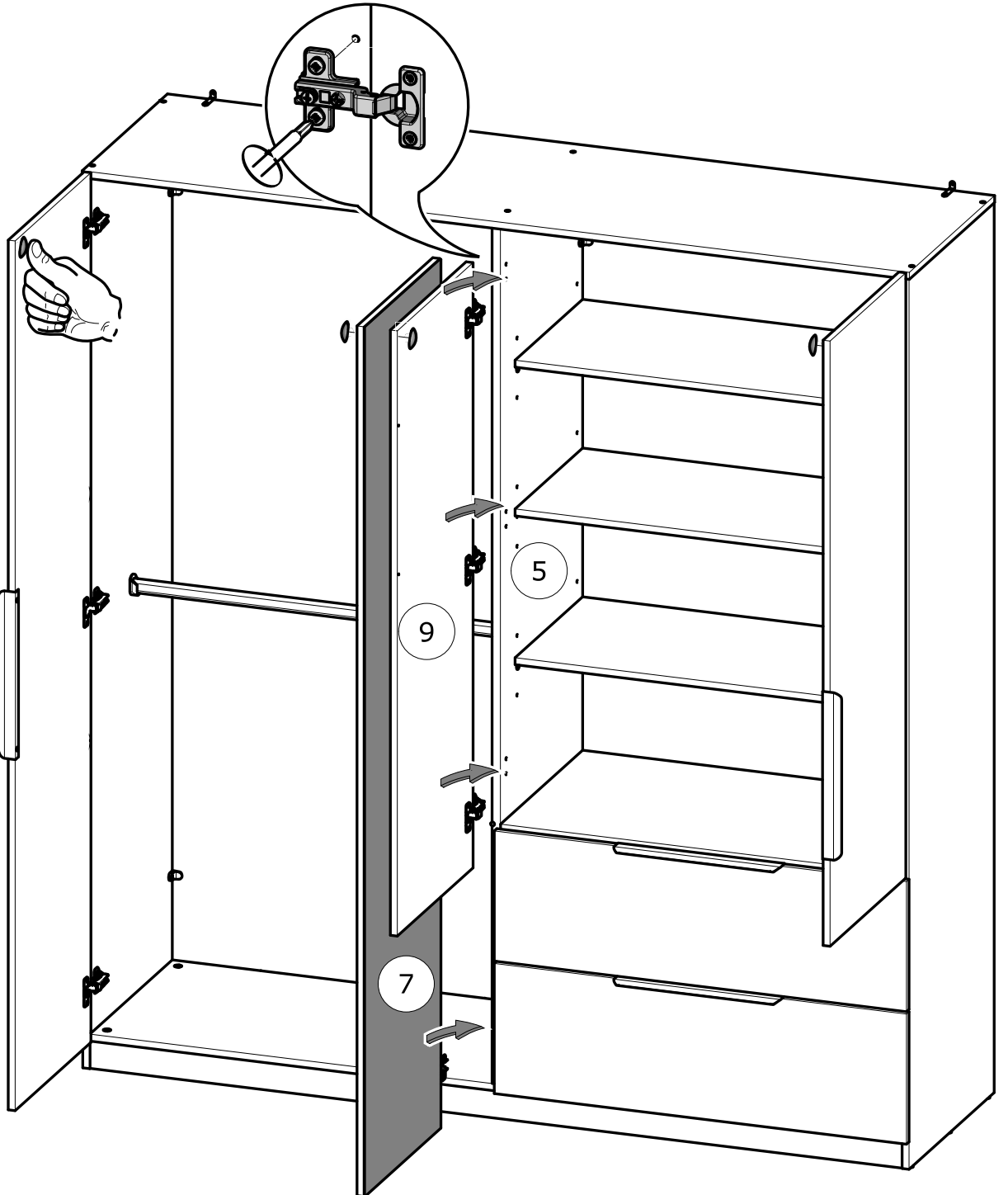

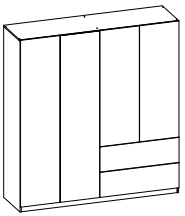

43

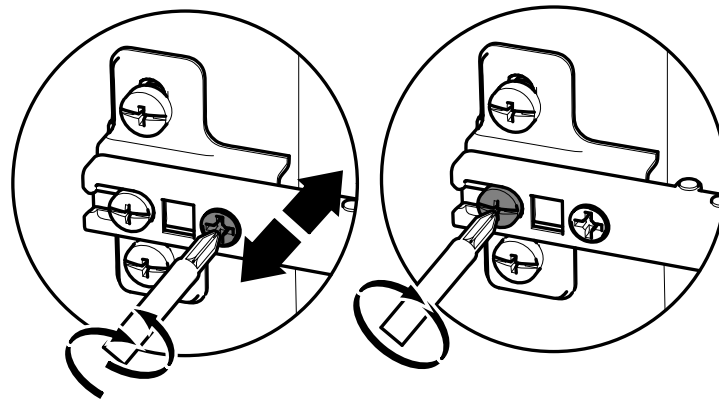
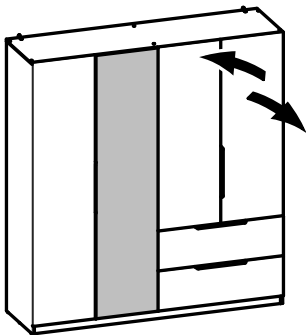
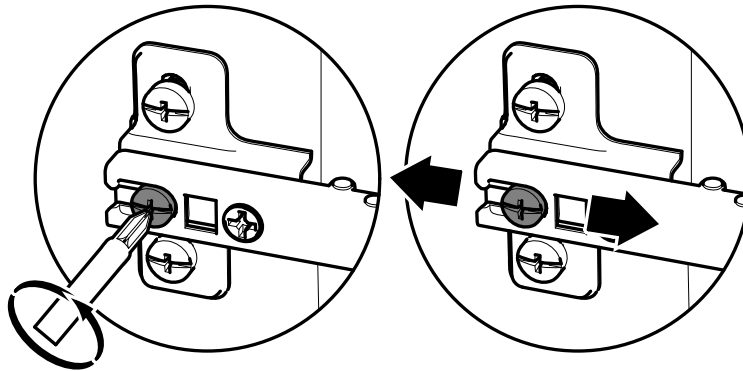
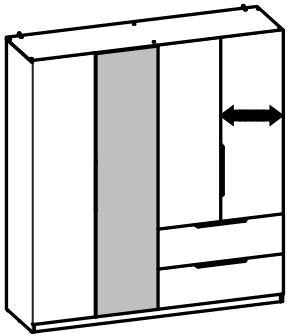
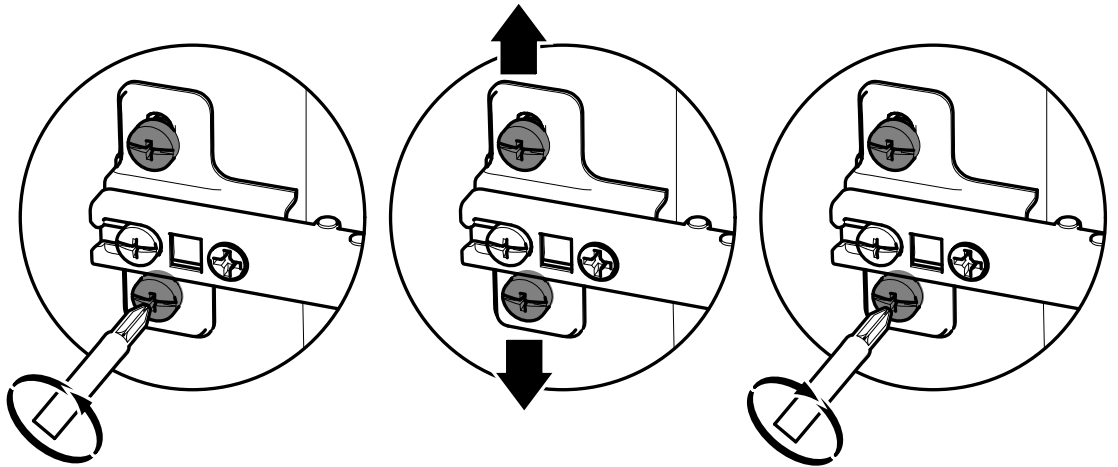
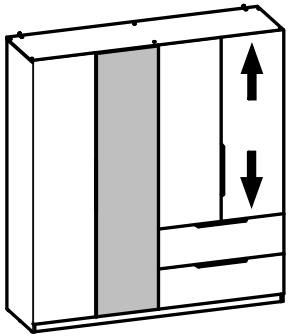

Les meubles contenant des panneaux à base de bois (panneaux de particules, panneaux de fibres, contreplaqué...) peuvent émettre des substances polluantes dans l'air intérieur.

Il est ainsi recommandé, après l'installation du meuble dans son logement, d'aérer fréquemment la pièce concernée pendant au moins quatre semaines" afin de réduire son exposition aux polluants émis par le meuble.